



Cisco HyperFlex HX-E-220M5SX Edge Node (Hybrid)

OVERVIEW	3
DETAILED VIEWS	4
Chassis Front View	4
Chassis Rear View	5
BASE NODE STANDARD CAPABILITIES and FEATURES	6
CONFIGURING the HyperFlex HX-E-220M5SX Edge Node	9
STEP 1 VERIFY SERVER SKU	10
STEP 2 SELECT CPU(s)	11
STEP 3 SELECT MEMORY	15
CPU DIMM Configuration Table	18
.....	19
STEP 4 SELECT RAID CONTROLLER	21
SAS HBA (internal HDD/SSD/JBOD support)	21
STEP 5 SELECT DRIVES	22
STEP 6 SELECT HYPERFLEX EDGE NETWORK TOPOLOGY	24
STEP 7 ORDER GPU CARDS (OPTIONAL)	25
STEP 8 SELECT OPTIONAL ADDITIONAL NICs	26
STEP 9 ORDER POWER SUPPLY	27
STEP 10 SELECT POWER CORD(s)	28
STEP 11 SELECT ACCESSORIES	31
STEP 12 ORDER SECURITY DEVICES (OPTIONAL)	32
STEP 13 ORDER TOOL-LESS RAIL KIT AND OPTIONAL REVERSIBLE CABLE MANAGEMENT ARM	33
STEP 14 SELECT OPERATION SYSTEM VERSION AND HYPERFLEX EDGE SUBSCRIPTION	34
STEP 15 SELECT HX DATA PLATFORM SOFTWARE	36
STEP 16 SELECT SERVICE and SUPPORT LEVEL	37
SUPPLEMENTAL MATERIAL	42
Supported Network Topologies for HyperFlex Edge 2 Node Deployments	42
10/25 Gigabit Ethernet Topology	43
1 Gigabit Ethernet Topology	44
Supported Network Topologies for HyperFlex Edge 3 and 4 Node Deployments	45
10/25 Gigabit Ethernet Topology	46
1 Gigabit Ethernet Dual Switch Topology	47
1 Gigabit Ethernet Single Switch Topology	48
CHASSIS	49
Serial Port Details	50
Upgrade and Servicing-Related Parts	51
KVM CABLE	52
DISCONTINUED EOL PRODUCTS	53
TECHNICAL SPECIFICATIONS	57
Dimensions and Weight	57
Power Specifications	58
Environmental Specifications	61
Extended Operating Temperature Hardware Configuration Limits	62
Compliance Requirements	63

OVERVIEW

Cisco HyperFlex™ Systems provides an all-purpose virtualized server platform, with hypervisor hosts, networking connectivity, and virtual server storage across a set of Cisco HX-Series x86 rack-mount servers. It combines the convergence of computing and networking provided by Cisco UCS, along with next-generation hyperconverged storage software, to uniquely provide the compute resources, network connectivity, storage, and hypervisor platform to run an entire virtual environment, all contained in a single uniform system.

Cisco HyperFlex Edge Systems are optimized for remote sites, branch offices, and edge environments. As a smaller form factor of Cisco HyperFlex, Cisco HyperFlex Edge keeps the full power of a next generation hyperconverged platform even without connecting to Cisco UCS Fabric Interconnects. Cisco HyperFlex Edge Systems support a variable configuration of 2, 3, or 4 HX converged nodes and supports the scale up of CPU, memory, and storage capacity (hot-add additional capacity drives).

HyperFlex Edge operates using existing top of rack 1GE or 10/25GE deployed in environments with a minimal infrastructure footprint, hence the use of UCS compute-only nodes is not supported.

The Cisco HyperFlex HX-E-220M5SX Edge Node is shown in [Figure 1](#).

The HX-E-220M5SX Edge servers extend the capabilities of Cisco's HyperFlex portfolio in a 1RU form factor with the addition of the 2nd Generation Intel® Xeon® Scalable Processors, 2933-MHz DDR4 DIMMs with DIMM capacity points up to 128 GB. The maximum memory capacity for 2 CPUs is listed here:

- 3 TB (24 x 128 GB DDR4 DIMMs)

Figure 1 Cisco HyperFlex HX-E-220M5SX Edge Node

Front View with Bezel Attached



Front View with Bezel Removed



Rear View (no VIC or PCIe adapters installed)



DETAILED VIEWS

Chassis Front View

Figure 2 shows the front view of the Cisco HyperFlex HX-E-220M5SX Edge Node

Figure 2 Chassis Front View

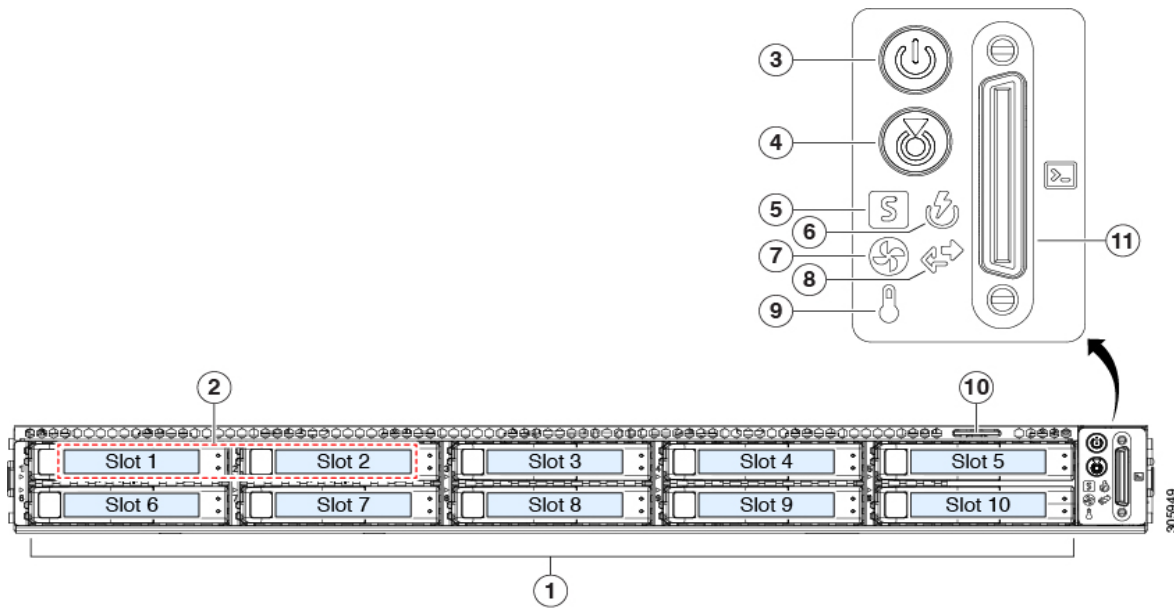

1	<p>Drive Slots</p> <ul style="list-style-type: none"> ■ Drive Slot 1 supports: <ul style="list-style-type: none"> • 1 x SATA/SAS SSD (For HyperFlex System/Log drive) ■ Drive Slot 2 supports: <ul style="list-style-type: none"> • 1 x SATA/SAS SSD (For Cache drive) ■ Drive Slot 3-10 supports: <ul style="list-style-type: none"> • 8 x SATA/SAS HDD (For Capacity drives) 	7	Fan status LED
2	N/A	8	Network link activity LED
3	Power button/Power status LED	9	Temperature status LED
4	Unit identification button/LED	10	Pull-out asset tag
5	System status LED	11	KVM connector (used with KVM cable that provides two USB 2.0, one VGA, and one serial connector)
6	Power supply status LED	—	—

Chassis Rear View

Figure 3 shows the external features of the rear panel.

Figure 3 Chassis Rear View

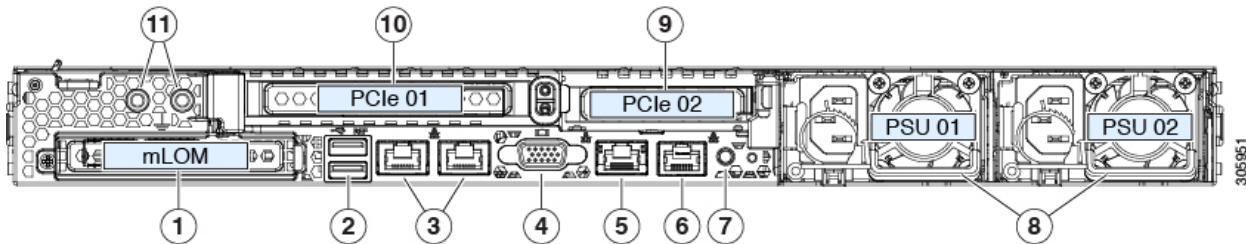

1	Modular LAN-on-motherboard (mLOM) card bay (x16)	7	Rear unit identification button/LED
2	USB 3.0 ports (two)	8	Power supplies (two, redundant as 1+1)
3	Dual 1/10GE Ethernet ports (LAN1 and LAN2). LAN1 is left connector and LAN2 is right connector NOTE: Only 1GE LOMs are supported on HX Edge nodes when using 1GE single or dual switch configurations for 3 or 4 nodes.	9	PCIe riser 2 (slot 2) (half-height, x16); NOTE: Use of PCIe riser 2 requires a dual CPU configuration.
4	VGA video port (DB-15)	10	PCIe riser 1 (slot 1) (full-height, x16)
5	1GE dedicated management port	11	Threaded holes for dual-hole grounding lug
6	Serial port (RJ-45 connector)	—	—

BASE NODE STANDARD CAPABILITIES and FEATURES

Table 1 lists the capabilities and features of the base server. Details about how to configure the server for a particular feature or capability (for example, number of processors, disk drives, or amount of memory) are provided in *CONFIGURING the HyperFlex HX-E-220M5SX Edge Node, page 9*.

Table 1 Capabilities and Features

Capability/Feature	Description
Chassis	One rack unit (1RU) chassis
CPU	One or two 2nd Generation Intel® Xeon® scalable family
Chipset	Intel® C621 series chipset
Memory	24 slots for Registered ECC DIMMs (RDIMMs), Load-Reduced DIMMs (LRDIMMs)
Multi-bit Error Protection	This server supports multi-bit error protection.
Video	<p>The Cisco Integrated Management Controller (CIMC) provides video using the Matrox G200e video/graphics controller:</p> <ul style="list-style-type: none"> ■ Integrated 2D graphics core with hardware acceleration ■ 512MB total DDR4 memory, with 16MB dedicated to Matrox video memory ■ Supports all display resolutions up to 1920 x 1200 x 32bpp resolution at 60Hz ■ High-speed integrated 24-bit RAMDAC ■ Single lane PCI-Express host interface ■ eSPI processor to BMC support
Power subsystem	<p>One or two of the following hot-swappable power supplies:</p> <ul style="list-style-type: none"> ■ 770 W (AC) ■ 1050 W (AC) ■ 1050 W (DC) ■ 1050 W (AC) ELV <p>NOTE: One power supply is mandatory; one more can be added for 1 + 1 redundancy.</p>
Front Panel	A front panel controller provides status indications and control buttons
ACPI	This server supports the advanced configuration and power interface (ACPI) 6.2 standard.
Fans	Seven hot-swappable fans for front-to-rear cooling

Table 1 Capabilities and Features (*continued*)

Capability/Feature	Description
Expansion slots	<ul style="list-style-type: none"> ■ Riser 1 (controlled by CPU 1): <ul style="list-style-type: none"> • One full-height profile, 3/4-length slot with x24 connector and x16 lane. ■ Riser 2 (controlled by CPU 2): <ul style="list-style-type: none"> • One half-height profile, half-length slot with x24 connector and x16 lane <p>NOTE: Use of PCIe riser 2 requires a dual CPU configuration.</p> ■ Dedicated SAS HBA slot (see Figure 10 on page 49) <ul style="list-style-type: none"> • An internal slot is reserved for use by the Cisco 12G SAS HBA.
Interfaces	<ul style="list-style-type: none"> ■ Rear panel <ul style="list-style-type: none"> • One 1Gbase-T RJ-45 management port (Marvell 88E6176) • Two 1/10Gbase-T LOM ports (Intel X550 controller embedded on the motherboard) • One RS-232 serial port (RJ45 connector) • One DB15 VGA connector • Two USB 3.0 port connectors • One flexible modular LAN on motherboard (mLOM) slot that can accommodate various interface cards ■ Front panel <ul style="list-style-type: none"> • One KVM console connector (supplies two USB 2.0 connectors, one VGA DB15 video connector, and one serial port (RS232) DB9 connector)
Internal storage devices	<p>Up to 10 Drives are installed into front-panel drive bays that provide hot-swappable access for SAS/SATA drives. 10 Drives are used as below:</p> <ul style="list-style-type: none"> • Three to Eight SATA/SAS HDD (for capacity) • One SATA/SAS SSD (for caching) • One SATA/SAS SSD (System drive for HyperFlex Operations) <p>NOTE: NVMe cache and capacity drives are not supported with HyperFlex Edge models.</p> <p>A mini-storage module connector on the motherboard for M.2 module for one M.2 SATA SSDs for following usage:</p> <ul style="list-style-type: none"> • ESXi hypervisor boot and HyperFlex storage controller VM <p>One slot for one micro-SD card on PCIe Riser 1 for following usage:</p> <ul style="list-style-type: none"> • The micro-SD card serves as a dedicated local resource for utilities such as host upgrade utility (HUU). Images can be pulled from a file share (NFS/CIFS) and uploaded to the cards for future use. Cisco Intersight leverages this card for advanced server management.

Table 1 Capabilities and Features (*continued*)

Capability/Feature	Description
Integrated management processor	<p>Baseboard Management Controller (BMC) running Cisco Integrated Management Controller (CIMC) firmware.</p> <p>Depending on your CIMC settings, the CIMC can be accessed through the 1GE dedicated management port, the 1GE/10GE LOM ports, or a Cisco virtual interface card (VIC).</p> <p>CIMC manages certain components within the server, such as the Cisco 12G SAS HBA and the Cisco VIC.</p>
Storage controller	<p>Cisco 12G SAS HBA (JBOD/Pass-through Mode)</p> <ul style="list-style-type: none"> ■ Supports up to 10 SAS/SATA internal drives ■ Plugs into the dedicated RAID controller slot
mLOM Slot	<p>The mLOM slot on the motherboard can flexibly accommodate the follow card:</p> <ul style="list-style-type: none"> ■ Cisco 1457 Quad Port Virtual Interface Card (10GE/25GE) <p>NOTE: VIC 1457 supports 10GE interface speeds (HyperFlex Release 4.0(1a) and later) or 25GE interfaces speeds (HyperFlex Release 4.0(2a) and later).</p> <p>HyperFlex with the 6400 Series Fabric Interconnects can support 10GE or 25GE</p>
(optional) Additional NICs	<p>PCIe slot 1 and PCIe slot 2 on the motherboard can flexibly accommodate the following cards:</p> <ul style="list-style-type: none"> ■ Intel X550-T2 dual port 10Gbase-T ■ Intel XXV710-DA2 dual port 25GE NIC ■ Intel i350 quad port 1Gbase-T ■ Intel X710-DA2 dual port 10GE NIC

CONFIGURING the HyperFlex HX-E-220M5SX Edge Node

For the most part, this system comes with a fixed configuration. Use these steps to see or change the configuration of the Cisco HX-E-220M5SX Edge Node:

- *STEP 1 VERIFY SERVER SKU, page 10*
- *STEP 2 SELECT CPU(s), page 11*
- *STEP 3 SELECT MEMORY, page 15*
- *STEP 4 SELECT RAID CONTROLLER, page 21*
- *STEP 5 SELECT DRIVES, page 22*
- *STEP 6 SELECT HYPERFLEX EDGE NETWORK TOPOLOGY, page 24*
- *STEP 7 ORDER GPU CARDS (OPTIONAL), page 25*
- *STEP 8 SELECT OPTIONAL ADDITIONAL NICs, page 26*
- *STEP 9 ORDER POWER SUPPLY, page 27*
- *STEP 10 SELECT POWER CORD(s), page 28*
- *STEP 11 SELECT ACCESSORIES, page 31*
- *STEP 12 ORDER SECURITY DEVICES (OPTIONAL), page 32*
- *STEP 13 ORDER TOOL-LESS RAIL KIT AND OPTIONAL REVERSIBLE CABLE MANAGEMENT ARM, page 33*
- *STEP 14 SELECT OPERATION SYSTEM VERSION AND HYPERFLEX EDGE SUBSCRIPTION, page 34*
- *STEP 15 SELECT HX DATA PLATFORM SOFTWARE, page 36*
- *SUPPLEMENTAL MATERIAL, page 42*

STEP 1 VERIFY SERVER SKU

Verify the product ID (PID) of the server as shown in [Table 2](#).

Table 2 PID of the HX-E-220M5SX Edge Node

Product ID (PID)	Description
HX-E-M5S-HXDP	This major line bundle (MLB) consists of the Server Node (HX-E-220M5SX) with HXDP software spare PIDs. Use this PID for creating estimates and placing orders.
HX-E-220M5SX ¹	HX220c M5 Edge Node, with one or two CPUs, memory, up to eight HDDs for data storage, one SSD (HyperFlex system drive), one SSD for caching, one or two power supplies, one M.2 SATA SSD (ESXi boot), one micro-SD card, optional PCIe cards, and optional rail kit.

Notes:

1. This product may not be purchased outside of the approved bundles (must be ordered under the MLB HX-E-M5S-HXDP).

The HX-E-220M5SX Edge Node:

- Requires configuration of one or two power supplies, one or two CPUs, recommended memory sizes, 1 SSD for Caching, 1 SSD for HyperFlex operations, 3 to 8 capacity HDDs, 1 M.2 SATA SSD and 1 micro-SD card.
- Requires selection of one HyperFlex network topology based on the top of rack switch configuration and network redundancy requirements. Selecting a topology automatically adds the necessary networking adapters to the configuration.



NOTE: Use the steps on the following pages to configure the server with the components that you want to include.

STEP 2 SELECT CPU(s)

The standard CPU features are:

- 2nd Generation Intel®Xeon® scalable family CPUs
- Intel C621 series chipset
- Cache size of up to 38.5 MB

Select CPUs

The available CPUs are listed in [Table 3](#).

Table 3 Available CPUs

Product ID (PID)	Clock Freq (GHz)	Power (W)	Cache Size (MB)	Cores	UPI ¹ Links (GT/s)	Highest DDR4 DIMM Clock Support (MHz)	Workload/Processor type ²
Cisco Recommended CPUs (2nd Generation Intel® Xeon® Processors)							
HX-CPU-I8276	2.2	165	38.50	28	3 x 10.4	2933	Oracle, SAP
HX-CPU-I8260	2.4	165	35.75	24	3 x 10.4	2933	Microsoft Azure Stack
HX-CPU-I6262V	1.9	135	33.00	24	3 x 10.4	2400	Virtual Server infrastructure or VSI
HX-CPU-I6248R	3.0	205	35.75	24	2 x 10.4	2933	2 nd Gen Intel® Xeon®
HX-CPU-I6248	2.5	150	27.50	20	3 x 10.4	2933	VDI, Oracle, SQL, Microsoft Azure Stack
HX-CPU-I6238R	2.2	165	38.50	28	2 x 10.4	2933	Oracle, SAP (2-Socket TDI only), Microsoft AzureStack
HX-CPU-I6238	2.1	140	30.25	22	3 x 10.4	2933	SAP
HX-CPU-I6230R	2.1	150	35.75	26	2 x 10.4	2933	Virtual Server Infrastructure, Data Protection, Big Data, Splunk, Microsoft AzureStack
HX-CPU-I6230	2.1	125	27.50	20	3 x 10.4	2933	Big Data, Virtualization
HX-CPU-I5220R	2.2	125	35.75	24	2 x 10.4	2666	Virtual Server Infrastructure, Splunk, Microsoft Azure Stack
HX-CPU-I5220	2.2	125	24.75	18	2 x 10.4	2666	HCI
HX-CPU-I5218R	2.1	125	27.50	20	2 x 10.4	2666	Virtual Server Infrastructure, Data Protection, Big Data, Splunk, Scale-out Object Storage, Microsoft AzureStack

Table 3 Available CPUs

Product ID (PID)	Clock Freq (GHz)	Power (W)	Cache Size (MB)	Cores	UPI ¹ Links (GT/s)	Highest DDR4 DIMM Clock Support (MHz)	Workload/Processor type ²
HX-CPU-I5218	2.3	125	22.00	16	2 x 10.4	2666	Virtualization, Microsoft Azure Stack, Splunk, Data Protection
HX-CPU-I4216	2.1	100	22.00	16	2 x 9.6	2400	Data Protection, Scale Out Storage
HX-CPU-I4214R	2.4	100	16.50	12	2 x 9.6	2400	Data Protection, Splunk, Scale-out Object Storage, Microsoft AzureStack
HX-CPU-I4214	2.2	85	16.50	12	2 x 9.6	2400	Data Protection, Scale Out Storage
HX-CPU-I4210R	2.4	100	13.75	10	2 x 9.6	2400	Virtual Server Infrastructure, Data Protection, Big Data, Splunk
HX-CPU-I4210	2.2	85	13.75	10	2 x 9.6	2400	Virtualization, Big Data, Splunk
8000 Series Processor							
HX-CPU-I8280L	2.7	205	38.50	28	3 x 10.4	2933	2 nd Gen Intel® Xeon®
HX-CPU-I8280	2.7	205	38.50	28	3 x 10.4	2933	2 nd Gen Intel® Xeon®
HX-CPU-I8276L	2.2	165	38.50	28	3 x 10.4	2933	2 nd Gen Intel® Xeon®
HX-CPU-I8276	2.2	165	38.50	28	3 x 10.4	2933	2 nd Gen Intel® Xeon®
HX-CPU-I8270	2.7	205	35.75	26	3 x 10.4	2933	2 nd Gen Intel® Xeon®
HX-CPU-I8268	2.9	205	35.75	24	3 x 10.4	2933	2 nd Gen Intel® Xeon®
HX-CPU-I8260Y	2.4	165	35.75	24/20/ 16	3 x 10.4	2933	2 nd Gen Intel® Xeon®
HX-CPU-I8260L	2.4	165	35.75	24	3 x 10.4	2933	2 nd Gen Intel® Xeon®
HX-CPU-I8260	2.4	165	35.75	24	3 x 10.4	2933	2 nd Gen Intel® Xeon®
6000 Series Processor							
HX-CPU-I6262V	1.9	135	33.00	24	3 x 10.4	2400	2 nd Gen Intel® Xeon®
HX-CPU-I6258R	2.7	205	35.75	28	2 x 10.4	2933	2 nd Gen Intel® Xeon®
HX-CPU-I6254	3.1	200	24.75	18	3 x 10.4	2933	2 nd Gen Intel® Xeon®
HX-CPU-I6252N	2.3	150	35.75	24	3 x 10.4	2933	2 nd Gen Intel® Xeon®
HX-CPU-I6252	2.1	150	35.75	24	3 x 10.4	2933	2 nd Gen Intel® Xeon®
HX-CPU-I6248R	3.0	205	35.75	24	2 x 10.4	2933	2 nd Gen Intel® Xeon®
HX-CPU-I6248	2.5	150	27.50	20	3 x 10.4	2933	2 nd Gen Intel® Xeon®
HX-CPU-I6246R	3.4	205	35.75	16	2 x 10.4	2933	2 nd Gen Intel® Xeon®
HX-CPU-I6246	3.3	165	24.75	12	3 x 10.4	2933	2 nd Gen Intel® Xeon®
HX-CPU-I6244	3.6	150	24.75	8	3 x 10.4	2933	2 nd Gen Intel® Xeon®

Table 3 Available CPUs

Product ID (PID)	Clock Freq (GHz)	Power (W)	Cache Size (MB)	Cores	UPI ¹ Links (GT/s)	Highest DDR4 DIMM Clock Support (MHz)	Workload/Processor type ²
HX-CPU-I6242R	3.1	205	35.75	20	2 x 10.4	2933	2 nd Gen Intel® Xeon®
HX-CPU-I6242	2.8	150	22.00	16	3 x 10.4	2933	2 nd Gen Intel® Xeon®
HX-CPU-I6240R	2.4	165	35.75	24	2 x 10.4	2933	2 nd Gen Intel® Xeon®
HX-CPU-I6240Y	2.6	150	24.75	18/14/8	3 x 10.4	2933	2 nd Gen Intel® Xeon®
HX-CPU-I6240L	2.6	150	24.75	18	3 x 10.4	2933	2 nd Gen Intel® Xeon®
HX-CPU-I6240	2.6	150	24.75	18	3 x 10.4	2933	2 nd Gen Intel® Xeon®
HX-CPU-I6238R	2.2	165	38.50	28	2 x 10.4	2933	2 nd Gen Intel® Xeon®
HX-CPU-I6238L	2.1	140	30.25	22	3 x 10.4	2933	2 nd Gen Intel® Xeon®
HX-CPU-I6238	2.1	140	30.25	22	3 x 10.4	2933	2 nd Gen Intel® Xeon®
HX-CPU-I6234	3.3	130	24.75	8	3 x 10.4	2933	2 nd Gen Intel® Xeon®
HX-CPU-I6230R	2.1	150	35.75	26	2 x 10.4	2933	2 nd Gen Intel® Xeon®
HX-CPU-I6230N	2.3	125	27.50	20	3 x 10.4	2933	2 nd Gen Intel® Xeon®
HX-CPU-I6230	2.1	125	27.50	20	3 x 10.4	2933	2 nd Gen Intel® Xeon®
HX-CPU-I6226R	2.9	150	22.00	16	2 x 10.4	2933	2 nd Gen Intel® Xeon®
HX-CPU-I6226	2.7	125	19.25	12	3 x 10.4	2933	2 nd Gen Intel® Xeon®
HX-CPU-I6222V	1.8	115	27.50	20	3 x 10.4	2400	2 nd Gen Intel® Xeon®
5000 Series Processor							
HX-CPU-I5220S	2.6	125	19.25	18	2 x 10.4	2666	2 nd Gen Intel® Xeon®
HX-CPU-I5220R	2.2	150	35.75	24	2 x 10.4	2666	2 nd Gen Intel® Xeon®
HX-CPU-I5220	2.2	125	24.75	18	2 x 10.4	2666	2 nd Gen Intel® Xeon®
HX-CPU-I5218R	2.1	125	27.50	20	2 x 10.4	2666	2 nd Gen Intel® Xeon®
HX-CPU-I5218B	2.3	125	22.00	16	2 x 10.4	2933	2 nd Gen Intel® Xeon®
HX-CPU-I5218N	2.3	105	22.00	16	2 x 10.4	2666	2 nd Gen Intel® Xeon®
HX-CPU-I5218	2.3	125	22.00	16	2 x 10.4	2666	2 nd Gen Intel® Xeon®
HX-CPU-I5217	3.0	115	11.00	8	2 x 10.4	2666	2 nd Gen Intel® Xeon®
HX-CPU-I5215L	2.5	85	13.75	10	2 x 10.4	2666	2 nd Gen Intel® Xeon®
HX-CPU-I5215	2.5	85	13.75	10	2 x 10.4	2666	2 nd Gen Intel® Xeon®
4000 Series Processor							
HX-CPU-I4216	2.1	100	22.00	16	2 x 9.6	2400	2 nd Gen Intel® Xeon®
HX-CPU-I4215R	3.2	130	11.00	8	2 x 9.6	2400	2 nd Gen Intel® Xeon®
HX-CPU-I4215	2.5	85	11.00	8	2 x 9.6	2400	2 nd Gen Intel® Xeon®
HX-CPU-I4214R	2.4	100	16.50	12	2 x 9.6	2400	2 nd Gen Intel® Xeon®
HX-CPU-I4214Y	2.2	85	16.50	12/10/8	2 x 9.6	2400	2 nd Gen Intel® Xeon®

Table 3 Available CPUs

Product ID (PID)	Clock Freq (GHz)	Power (W)	Cache Size (MB)	Cores	UPI ¹ Links (GT/s)	Highest DDR4 DIMM Clock Support (MHz)	Workload/Processor type ²
HX-CPU-I4214	2.2	85	16.50	12	2 x 9.6	2400	2 nd Gen Intel® Xeon®
HX-CPU-I4210R	2.4	100	13.75	10	2 x 9.6	2400	2 nd Gen Intel® Xeon®
HX-CPU-I4210	2.2	85	13.75	10	2 x 9.6	2400	2 nd Gen Intel® Xeon®
HX-CPU-I4208	2.1	85	11.00	8	2 x 9.6	2400	2 nd Gen Intel® Xeon®
3000 Series Processor							
HX-CPU-I3206R	1.9	85	11.00	8	2 x 9.6	2133	2 nd Gen Intel® Xeon®

Notes:

1. UPI = Ultra Path Interconnect. 2-socket servers support only 2 UPI performance, even if the CPU supports 3 UPI.
2. HyperFlex Data Platform reserves CPU cycle for each controller VM. Refer to the <[Install Guide](#)> for reservation details.



CAUTION: For systems configured with 2nd Gen Intel® Xeon® 205W R-series processors, operating above 30° C [86° F], a fan fault or executing workloads with extensive use of heavy instructions sets like Intel® Advanced Vector Extensions 512 (Intel® AVX-512), may assert thermal and/or performance faults with an associated event recorded in the System Event Log (SEL).

- **HX-CPU-I6258R** - Intel 6258R 2.7GHz/205W 28C/35.75MB DDR4 2933MHz
- **HX-CPU-I6248R** - Intel 6248R 3.0GHz/205W 24C/35.75MB DDR4 2933MHz
- **HX-CPU-I6246R** - Intel 6246R 3.4GHz/205W 16C/35.75MB DDR4 2933MHz
- **HX-CPU-I6242R** - Intel 6242R 3.1GHz/205W 20C/35.75MB DDR4 2933MHz

Approved Configurations

(1) 1-CPU Configuration:

- Select any one CPU listed in [Table 3 on page 11](#).
- Requires 10 Core and above CPUs.

(2) 2-CPU Configuration:

- Select two identical CPUs from any one of the rows of [Table 3 on page 11](#).

STEP 3 SELECT MEMORY

The standard memory features are:

- Clock speed: Up to 2933 MHz; See available CPUs and their associated DDR4 DIMM maximum clock support in [Table 3](#).
- Rank per DIMM: 1, 2, 4, or 8
- Operational voltage: 1.2 V
- Registered ECC DDR4 DIMMS (RDIMMs), Load-reduced DIMMs (LRDIMMs)

Memory is organized with six memory channels per CPU, with up to two DIMMs per channel, as shown in [Figure 4](#).

Figure 4 HX-E-220M5SX Edge Node Memory Organization

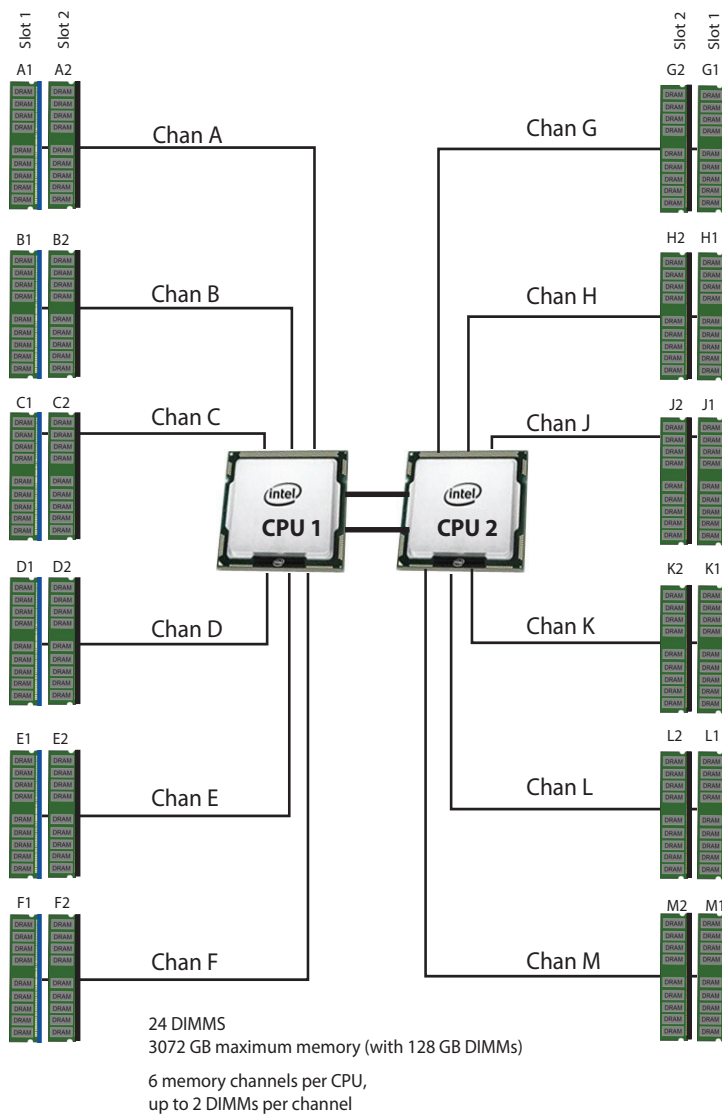

Select DIMMs

Select the memory configuration. The available memory DIMMs are listed in [Table 4](#)



NOTE: The memory mirroring feature is not supported with HyperFlex nodes.

Table 4 Available DDR4 DIMMs

Product ID (PID)	PID Description	Voltage	Ranks/ DIMM
HX-ML-128G4RT-H ¹	128 GB DDR4-2933MHz LRDIMM/4Rx4 (16Gb)	1.2 V	4
HX-ML-X64G4RT-H ¹	64 GB DDR4-2933MHz LRDIMM/4Rx4 (8Gb)	1.2 V	4
HX-MR-X64G2RT-H ¹	64 GB DDR4-2933MHz RDIMM/2Rx4 (16Gb)	1.2 V	2
HX-MR-X32G2RT-H ¹	32GB DDR4-2933MHz RDIMM/2Rx4 (8Gb)	1.2 V	2
HX-MR-X16G1RT-H ¹	16 GB DDR4-2933MHz RDIMM/1Rx4 (8Gb)	1.2 V	1
HX-ML-128G4RW ²	128GB DDR4-3200MHz LRDIMM 4Rx4 (16Gb)	1.2 V	1
HX-MR-X64G2RW ²	64GB DDR4-3200MHz RDIMM 2Rx4 (16Gb)	1.2 V	1
HX-MR-X32G2RW ²	32GB DDR4-3200MHz RDIMM 2Rx4 (8Gb)	1.2 V	1
HX-MR-X16G1RW ²	16GB DDR4-3200MHz RDIMM 1Rx4 (8Gb)	1.2 V	1

Notes:

1. Cisco announced the End-of-sale of the DDR4-2933MHz Memory DIMM products: [EOL14611](#) lists the product part numbers affected by this announcement. [Table 5](#) describes the replacement Memory DIMM product Part Numbers.
2. DDR4-3200MHz replacement part numbers will operate at the maximum speed of the Intel 2nd generation Xeon Scalable processor memory interface, ranging from 2133 MHz to 2933 MHz.

Table 5 lists the EOL Memory DIMM product part numbers and their replacement PIDs.

Table 5 EOL14611 Memory DIMM Product Part Numbers and their replacement PIDs

EOS Product Part Number (PID)	PID Description	Replacement Product PID	Replacement Product Description
HX-MR-X16G1RT-H	16GB DDR4-2933MHz RDIMM 1Rx4 (8Gb)/1.2v	HX-MR-X16G1RW	16GB DDR4-3200MHz RDIMM 1Rx4 (8Gb)/1.2v
HX-MR-X32G2RT-H	32GB DDR4-2933MHz RDIMM 2Rx4 (8Gb)/1.2v	HX-MR-X32G2RW	32GB DDR4-3200MHz RDIMM 2Rx4 (8Gb)/1.2v
HX-MR-X64G2RT-H	64GB DDR4-2933MHz RDIMM 2Rx4 (16Gb)/1.2v	HX-MR-X64G2RW	64GB DDR4-3200MHz RDIMM 2Rx4 (16Gb)/1.2v
HX-ML-X64G4RT-H	64GB DDR4-2933MHz LRDIMM 4Rx4 (8Gb)/1.2v	HX-MR-X64G2RW ¹	64GB DDR4-3200MHz RDIMM 2Rx4 (16Gb)/1.2v
HX-ML-128G4RT-H	128GB DDR4-2933MHz LRDIMM 4Rx4 (16Gb)/1.2v	HX-ML-128G4RW	128GB DDR4-3200MHz LRDIMM 4Rx4 (16Gb)/1.2v



NOTE: (1) Cisco doesn't support a Load Reduce DIMM (LRDIMM) 64GB Memory PID as a replacement PID of existing UCS-ML-x64G4RT-H and recommends migrating to the Registered DIMM (RDIMM) instead, delivering the best balance in performance and price.

CPU DIMM Configuration Table

Approved Configurations

(1) 1-CPU configuration

- Select from 1 to 12 DIMMs.

CPU 1 DIMM Placement in Channels (for identically ranked DIMMs)	
1	(A1)
2	(A1, B1)
3	(A1, B1, C1)
4	(A1, B1); (D1, E1)
6	(A1, B1); (C1, D1); (E1, F1)
8	(A1, B1); (D1, E1); (A2, B2); (D2, E2)
12	(A1, B1); (C1, D1); (E1, F1); (A2, B2); (C2, D2); (E2, F2)

(2) 2-CPU configuration

- Select from 1 to 12 DIMMs per CPU.

	CPU 1 DIMM Placement in Channels (for identical ranked DIMMs)	CPU 2 DIMM Placement in Channels (for identical ranked DIMMs)
	CPU 1	CPU 2
1	(A1)	(G1)
2	(A1, B1)	(G1, H1)
3	(A1, B1, C1)	(G1, H1, J1)
4	(A1, B1); (D1, E1)	(G1, H1); (K1, L1)
6	(A1, B1); (C1, D1); (E1, F1)	(G1, H1); (J1, K1); (L1, M1)
8	(A1, B1); (D1, E1); (A2, B2); (D2, E2)	(G1, H1); (K1, L1); (G2, H2); (K2, L2)
12	(A1, B1); (C1, D1); (E1, F1); (A2, B2); (C2, D2); (E2, F2)	(G1, H1); (J1, K1); (L1, M1); (G2, H2); (J2, K2); (L2, M2)

**NOTE:**

- The selected DIMMs must be all of same type and number of DIMMs must be equal for both CPUs
- Even though 128GB of DRAM is supported, It is recommended to have a minimum of 192GB of DRAM configured for maximum performance
- HyperFlex Data Platform reserves memory for each controller VM. Refer to the <[Install Guide](#)> for reservation details.
- Recommended 6 or 12 DIMMs per CPU.
- Refer to “[CPU DIMM Configuration Table](#)” for the configuration details

System Speed

Memory will operate at the maximum speed of the Intel Xeon Scalable processor memory controller, ranging from 2133 MHz to 2933 MHz for M5 servers. Check CPU specifications for supported speeds



NOTE: Detailed mixing DIMM configurations are described in Cisco UCS [M5 Memory Guide](#)

Table 6 2933-MHz DIMM Memory Speeds with Different 2nd Generation Intel® Xeon® Scalable Processors

DIMM and CPU Frequencies (MHz)	DPC	LRDIMM (4Rx4)-128 GB (MHz)	LRDIMM (4Rx4) - 64 GB (MHz)	RDIMM (2Rx4) - 64 GB (MHz)	RDIMM (2Rx4) - 32 GB (MHz)	RDIMM (1Rx4) - 16 GB (MHz)
		1.2 V	1.2 V	1.2 V	1.2 V	1.2 V
DIMM = 2933 CPU = 2933	1DPC	2933	2933	2933	2933	2933
	2DPC	2933	2933	2933	2933	2933
DIMM = 2933 CPU = 2666	1DPC	2666	2666	2666	2666	2666
	2DPC	2666	2666	2666	2666	2666

Table 6 2933-MHz DIMM Memory Speeds with Different 2nd Generation Intel® Xeon® Scalable Processors

DIMM and CPU Frequencies (MHz)	DPC	LRDIMM (4Rx4)-128 GB (MHz)	LRDIMM (4Rx4) - 64 GB (MHz)	RDIMM (2Rx4) - 64 GB (MHz)	RDIMM (2Rx4) - 32 GB (MHz)	RDIMM (1Rx4) - 16 GB (MHz)
DIMM = 2933 CPU = 2400	1DPC	2400	2400	2400	2400	2400
	2DPC	2400	2400	2400	2400	2400
DIMM = 2933 CPU = 2133	1DPC	2133	2133	2133	2133	2133
	2DPC	2133	2133	2133	2133	2133

STEP 4 SELECT RAID CONTROLLER

SAS HBA (internal HDD/SSD/JBOD support)

Choose the following SAS HBA for internal drive connectivity (non-RAID):

- The Cisco 12G SAS HBA, which plugs into a dedicated RAID controller slot.

Select Controller Options

Select the following:

- Cisco 12 Gbps Modular SAS HBA (see [Table 7](#))

Table 7 Hardware Controller Options

Product ID (PID)	PID Description
Controllers for Internal Drives	
Note that the following Cisco 12G SAS HBA controller is factory-installed in the dedicated internal slot.	
HX-SAS-M5	Cisco 12G SAS HBA <ul style="list-style-type: none">■ Supports up to 10 internal SAS HDDs and SAS/SATA SSDs■ Supports JBOD mode only for use with HyperFlex Data Platform software.■ The HyperFlex Data Platform performs its own internal data replication for high availability. Hence, no RAID functionality is used.

Approved Configurations

The Cisco 12 Gbps Modular SAS HBA supports up to 10 internal drives.

STEP 5 SELECT DRIVES

The standard disk drive features are:

- 2.5-inch small form factor
- Hot-pluggable
- Drives come mounted in sleds

Select Drives

The available drives are listed in [Table 8](#)

Table 8 Available Hot-Pluggable Sled-Mounted Drives

Product ID (PID)	PID Description	Drive Type	Capacity
Front Capacity Drive			
HX-HD12TB10K12N	1.2TB 2.5 inch 12G SAS 10K RPM HDD	SAS	1.2 TB
HX-HD18TB10K4KN	1.8TB 2.5 inch 12G SAS 10K RPM HDD	SAS	1.8 TB
HX-HD24TB10K4KN	2.4TB 12G SAS 10K RPM SFF HDD (4K) (HyperFlex Release 4.0(1a) and later)	SAS	2.4 TB
Front cache Drive			
HX-SD480G63X-EP	480GB 2.5 inch Enterprise Performance 6G SATA SSD (3X endurance)	SATA	480 GB
HX-SD800GK3X-EP	800GB 2.5in Enterprise Performance 12G SAS SSD(3X endurance)	SAS	800 GB
Front System Drive			
HX-SD240GM1X-EV	240GB 2.5 inch Enterprise Value 6G SATA SSD (HyperFlex Release 3.5(2a) and later)	SATA	240GB
Boot Drives			
HX-M2-240GB	240GB SATA M.2 SSD	SATA	240 GB
HX-M2-HWRAID ¹	Cisco Boot optimized M.2 Raid controller (HyperFlex Release 4.5(1a) and later)		

NOTE: Cisco uses solid state drives (SSDs) from a number of vendors. All solid state drives (SSDs) are subject to physical write limits and have varying maximum usage limitation specifications set by the manufacturer. Cisco will not replace any solid state drives (SSDs) that have exceeded any maximum usage specifications set by Cisco or the manufacturer, as determined solely by Cisco.

Notes:

1. A maximum of one HX-M2-240GB or HX-M2-960GB is allowed when HX-M2-HWRAID is not selected. Either reduce Qty of HX-M2-240GB or HX-M2-960GB to 1 or add HX-M2-HWRAID

Approved Configurations

Select the following drives:

- 3 to 8 capacity drives -



NOTE:

- A minimum of 3 capacity drives is supported for HX Edge.
 - For cluster scale related information please see the product [release notes](#)
-

- One cache drive
- One system drive
- One boot drive



NOTE:

- It is recommended that M.2 SATA SSDs be used as boot-only devices.
 - CIMC/UCSM is supported for configuring of volumes and monitoring of the controller and installed SATA M.2 drives.
 - The minimum version of Cisco IMC and Cisco UCS Manager that supports this controller is 4.2(1) and later. The name of the controller in the software is MSTOR-RAID
 - The SATA M.2 drives can boot in UEFI mode only. Legacy boot mode is not supported.
 - Hot-plug replacement is not supported. The server must be powered off.
 - **RAID Support for Boot Drives:** Support for Hardware RAID M.2 boot drives in HyperFlex converged and compute-only nodes. Requires optional HX-M2-HWRAID controller with two boot drives. Existing single boot drive option remains supported.
 - This is supported starting from 4.5 (1a) version and later. please check the [release notes](#) for the further information
-

Caveats

You must choose from three up to eight HDD capacity drives, one caching drive, one system drive and one boot drive.

- Self Encrypting Drives (SEDs) are not supported for HX Edge configurations
- NVMe and Optane cache drives are not supported for HX Edge configurations.

STEP 6 SELECT HYPERFLEX EDGE NETWORK TOPOLOGY

HyperFlex Edge utilizes the existing top of rack (ToR) switches available in the customer environment.

Many topologies are supported to ensure the right fit for many environments. HyperFlex Edge supports single and dual switch topologies, depending on the level of high availability required. See the [SUPPLEMENTAL MATERIAL, page 42](#) for more details on each topology option.

Select one network topology from the options listed in [Table 9](#).

Table 9 Edge network category

Product ID (PID)	PID Description
HX-E-TOPO1 ^{1,2}	10/25 GE Single or Dual Switch (2, 3, or 4 node)
HX-E-TOPO2	1 GE Dual Switch (3 or 4 node), 1GbE Dual or Single (2 node)
HX-E-TOPO3	1 GE Single Switch (3 or 4 node only)

Notes:

1. Data Platform software version 4.0(1a) and later is required when ordering **HX-E-TOPO1**.
2. Data Platform software version 4.0 (2a) and later is required when configuring 25GE interface speeds



NOTE:

- A topology selection is required. Optional Intel NIC adapters in Step 7 are used by guest VMs/applications only. These adapters may not be substituted for the adapters automatically included when selecting a topology.
 - Selecting **HX-E-TOPO1** will include the VIC 1457 mLOM card for 10/25GE topologies. 10GE is supported with HyperFlex Edge starting with HyperFlex Release 4.0(1a) and later. 25GE may be used with HyperFlex Release 4.0(2a) and later. Two ports on the 10GE are used for HyperFlex functions. The remaining two ports may be used by applications after the HyperFlex deployment is completed.
 - Selecting **HX-E-TOPO2** will include the Intel i350 quad port PCIe NIC for 1GE topologies. Two ports on the NIC are used for HyperFlex functions. The remaining two ports may be used by applications after the HyperFlex deployment is completed.
 - vSphere 6.5 or later factory installed option is required when selecting **HX-E-TOPO1**
 - Cisco strongly recommends **HX-E-TOPO1** for all new deployments for the following reasons:
 - Higher storage performance
 - Expansion ready - Ability to support node expansion in a future HyperFlex Data Platform software release.
 - Investment protection provides up to 100GE of theoretical throughput per server.
 - Leaves PCIe slots free for accessories
-

STEP 7 ORDER GPU CARDS (OPTIONAL)

The available GPU PCIe options are listed in [Table 10](#)

Table 10 Available PCIe Option Cards

Product ID (PID)	PID Description	Card Height	Maximum cards Per node
GPU PCIe Cards			
HX-GPU-T4-16	NVIDIA T4 PCIE 75W 16GB	Low Profile Single-Width	2



NOTE: All GPU cards must be procured from Cisco as there is a unique SBIOS ID required by CIMC and UCSM

Caveats

- GPUs cannot be mixed.
- A GPU can be installed in either PCIe slot 1 or 2; however, for 1-CPU systems, only slot 1 is available. In 2-CPU systems, matching GPUs can be installed in both slots.

STEP 8 SELECT OPTIONAL ADDITIONAL NICs

HyperFlex Edge supports the use of additional PCIe NIC cards for use by guest VMs or applications running on top of HyperFlex. For full details see the [HyperFlex Networking Topologies Tech Note](#).

Select PCIe Option Card

The available PCIe option card are listed in [Table 11](#).

Table 11 Available PCIe Option Cards

Product ID (PID)	PID Description	Card Height
Network Interface Card (NIC)		
HX-PCIE-IRJ45	Intel i350 Quad Port 1Gb Adapter	Half
HX-PCIE-ID10GF	Intel X710-DA2 dual-port 10G SFP+ NIC	*HHHL
HX-PCIE-ID10GC	Intel X550-T2 dual-port 10GBase-T NIC	*HHHL
HX-PCIE-ID25GF	Intel XXV710-DA2 10-dual-port 25G NIC	*HHHL
* HHHL= Half Height Half length		



NOTE:

- The number of additional NICs supported depends on the HyperFlex network topology selected and the number of physical CPUs configured.
- These additional adapters are optional and may not be substituted for an HX Edge network topology selection.
- This list is non-exhaustive. For a complete list of compatible NICs, refer to the UCS HCL tool and search for the C220-M5SX to determine adapter compatibility.
- Connections to optional NIC adapters must be in a link-down or disconnected state during HyperFlex deployment.

The number of supported optional adapters depends on the number of CPUs configured and the HyperFlex Edge network topology selected:

Single CPU

- One additional PCIe card may be added with HX-E-TOPO1 or HX-E-TOPO3 selections.
- No additional PCIe cards may be added with HX-E-TOPO2 selection.

Dual CPU

- One or two additional PCIe cards may be added with HX-E-TOPO1 or HX-E-TOPO3 selections.
- One additional PCIe card may be added with HX-E-TOPO2 selection.

STEP 9 ORDER POWER SUPPLY

Power supplies share a common electrical and physical design that allows for hot-plug and tool-less installation into HX-E-220M5SX Edge Nodes. Each power supply is certified for high-efficiency operation and offers multiple power output options. This allows users to “right-size” based on server configuration, which improves power efficiency, lowers overall energy costs and avoids stranded capacity in the data center. Use the power calculator at the following link to determine the needed power based on the options chosen (CPUs, drives, memory, and so on):

<http://ucspowercalc.cisco.com>

Select one or two power supplies from the list in *Table 12*

Table 12 Power Supply

Product ID (PID)	PID Description
HX-PSU1-770W	770W AC power supply for C-Series Servers
HX-PSU1-1050W	1050W AC power supply for C-Series servers
HX-PSUV2-1050DC	1050W DC power supply for C-Series servers
HX-PSU1-1050ELV	1050W AC Power Supply for Rack Server Low Line



NOTE: In a server with two power supplies, both power supplies must be identical.

STEP 10 SELECT POWER CORD(S)

Using [Table 13](#), select the appropriate AC power cords. You can select zero to two power cords. If you select the option R2XX-DMYMPWRCORD, no power cord is shipped with the server.

Table 13 Available Power Cords

Product ID (PID)	PID Description	Images
R2XX-DMYMPWRCORD	No power cord (dummy PID to allow for a no power cord option)	Not applicable
CAB-48DC-40A-8AWG	C-Series -48VDC PSU Power Cord, 3.5M, 3 Wire, 8AWG, 40A	<p>Figure 1-3 CAB-48DC-40A-8AWG, DC Power Cord (3.5 m)</p> 
CAB-N5K6A-NA	Power Cord, 200/240V 6A, North America	
CAB-AC-L620-C13	AC Power Cord, NEMA L6-20 - C13, 2M/6.5ft	
CAB-C13-CBN	CABASY,WIRE,JUMPER CORD, 27" L, C13/C14, 10A/250V	
CAB-C13-C14-2M	CABASY,WIRE,JUMPER CORD, PWR, 2 Meter, C13/C14,10A/250V	
CAB-C13-C14-AC	CORD,PWR,JMP,IEC60320/C14,IEC60320/C13, 3.0M	

Table 13 Available Power Cords

Product ID (PID)	PID Description	Images
CAB-250V-10A-AR	Power Cord, 250V, 10A, Argentina	 <p>Plug: EL 219 (IRAM 2073)</p> <p>Cordset rating: 10 A, 250/500 V MAX Length: 8.2 ft</p> <p>Connector: EL 701 (IEC60320/C13)</p>
CAB-9K10A-AU	Power Cord, 250VAC 10A 3112 Plug, Australia	 <p>Plug: EL 210 (BS 1363A) 13 AMP fuse</p> <p>Cordset rating: 10 A, 250 V/500 V MAX Length: 2500mm</p> <p>Connector: EL 701C (EN 60320/C15)</p>
CAB-250V-10A-CN	AC Power Cord - 250V, 10A - PRC	 <p>Plug: M2511</p> <p>Cordset rating: 10A/16 A, 250 V Length: 8 ft 2 in. (2.5 m)</p> <p>Connector: VSCC15</p>
CAB-9K10A-EU	Power Cord, 250VAC 10A CEE 7/7 Plug, EU	 <p>Plug: EL 208</p> <p>Cordset rating: 16A, 250V (2500mm)</p> <p>Connector: EL 701</p>
CAB-250V-10A-ID	Power Cord, 250V, 10A, India	 <p>Plug: EL 212 (SI-32)</p> <p>Cordset rating: 10A, 250V/500V MAX (2500 mm)</p> <p>Connector: EL 701B (IEC60320/C13)</p>
CAB-9K10A-IT	Power Cord, 250VAC 10A CEI 23-16/VII Plug, Italy	 <p>Plug: I/3G (CEI 23-16)</p> <p>Cordset rating: 10 A, 250 V Length: 8 ft 2 in. (2.5 m)</p> <p>Connector: C15M (EN60320/C15)</p>
CAB-9K10A-SW	Power Cord, 250VAC 10A MP232 Plug, Switzerland	 <p>Plug: MP232-R</p> <p>Cordset rating: 10 A, 250 V Length: 8 ft. 2 in (2.5 m)</p> <p>Connector: IEC 60320 C15</p>

Table 13 Available Power Cords

Product ID (PID)	PID Description	Images
CAB-9K10A-UK	Power Cord, 250VAC 10A BS1363 Plug (13 A fuse), UK	
CAB-9K12A-NA	Power Cord, 125VAC 13A NEMA 5-15 Plug, North America	
CAB-250V-10A-BR	Power Cord - 250V, 10A - Brazil	
CAB-C13-C14-2M-JP	Power Cord C13-C14, 2M/6.5ft Japan PSE mark	Image not available
CAB-9K10A-KOR	Power Cord, 125VAC 13A KSC8305 Plug, Korea	Image not available
CAB-ACTW	AC Power Cord (Taiwan), C13, EL 302, 2.3M	Image not available
CAB-JPN-3PIN	Japan, 90-125VAC 12A NEMA 5-15 Plug, 2.4m	Image not available
CAB-48DC-40A-INT	-48VDC PSU PWR Cord, 3.5M, 3 Wire, 8AWG, 40A (INT)	Image Not available
CAB-48DC-40A-AS	-48VDC PSU PWR Cord, 3.5M, 3Wire, 8AWG, 40A (AS/NZ)	Image Not available
CAB-C13-C14-IN ¹	Power Cord Jumper,C13-C14 Connectors,1.4 Meter Length, India	Image Not available
CAB-C13-C14-3M-IN ¹	Power Cord Jumper, C13-C14 Connectors, 3 Meter Length, India	Image Not available

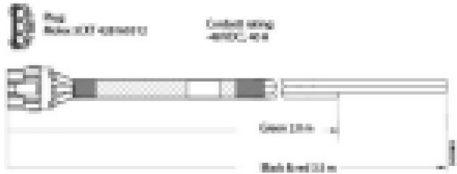
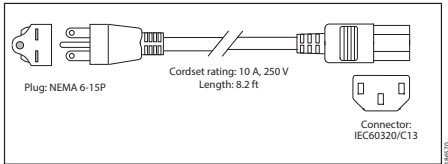
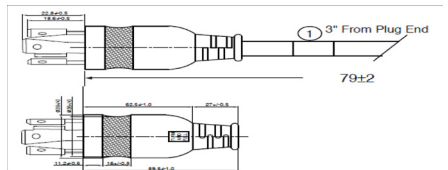
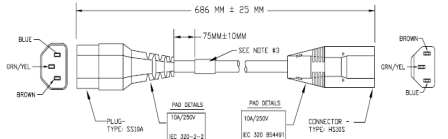
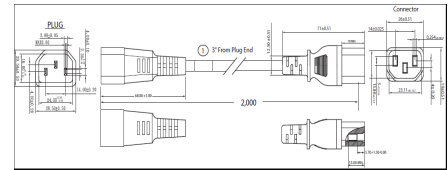
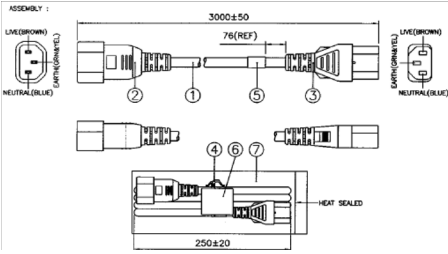
Notes:

1. These new replacement parts for cards in compliance with the Dec 1st, 2020 Bureau of Indian Standards (BIS) regulatory standard for lower-power consumption products.

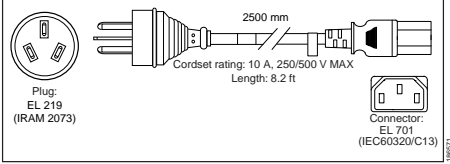
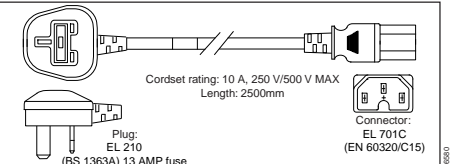
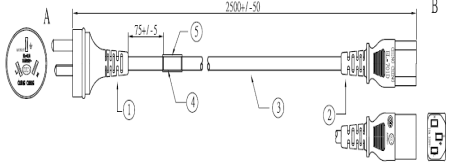
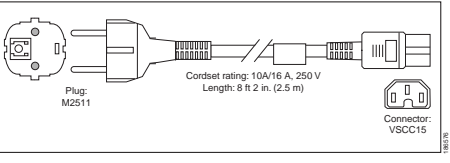
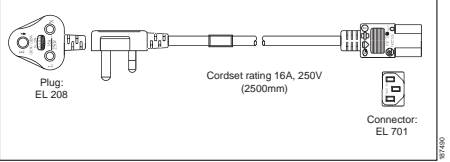
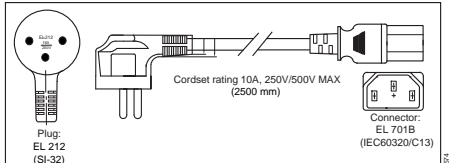
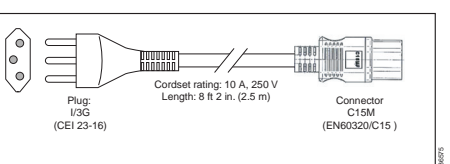
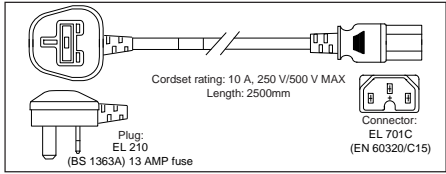
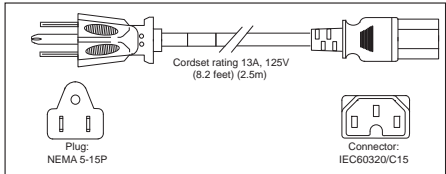
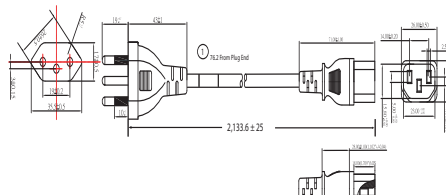
STEP 11 SELECT ACCESSORIES

Select

- Internal micro SD Card Module HX-MSD-32G from [Table 14](#)

Table 14 Internal microSD Card Module

Product ID (PID)	PID Description
HX-MSD-32G	32GB Micro-SD Card for UCS servers



NOTE:

- This is a required component.
 - The micro-SD card mounts internally on riser 1.
 - The micro-SD card serves as a dedicated local resource for utilities such as HUU. Images can be pulled from a file share (NFS/CIFS) and uploaded to the cards for future use.
-

STEP 12 ORDER SECURITY DEVICES (OPTIONAL)

A Trusted Platform Module (TPM) is a computer chip (microcontroller) that can securely store artifacts used to authenticate the platform (server). These artifacts can include passwords, certificates, or encryption keys. A TPM can also be used to store platform measurements that help ensure that the platform remains trustworthy. Authentication (ensuring that the platform can prove that it is what it claims to be) and attestation (a process helping to prove that a platform is trustworthy and has not been breached) are necessary steps to ensure safer computing in all environments.

A chassis intrusion switch gives a notification of any unauthorized mechanical access into the server.

The security device ordering information is listed in [Table 15](#).

Table 15 Security Devices

Product ID (PID)	PID Description
HX-TPM2-002	Trusted Platform Module 2.0 for UCS servers
HX-TPM2-002B	Trusted Platform Module 2.0 M5 UCS servers (FIPS 140-2 Compliant)
HX-INT-SW01	C220 M5 and C240 M5 Chassis Intrusion Switch



NOTE:

- The TPM module used in this system conforms to TPM v2.0, as defined by the Trusted Computing Group (TCG). It is also SPI-based.
 - TPM installation is supported after-factory. However, a TPM installs with a one-way screw and cannot be replaced, upgraded, or moved to another server. If a server with a TPM is returned, the replacement server must be ordered with a new TPM.
-

STEP 13 ORDER TOOL-LESS RAIL KIT AND OPTIONAL REVERSIBLE CABLE MANAGEMENT ARM

Select a Tool-Less Rail Kit

Select a tool-less rail kit from [Table 16](#).

Table 16 Tool-less Rail Kit Options

Product ID (PID)	PID Description
HX-RAILF-M4	Friction Rail Kit for HX-E-220M5SX Edge Nodes
HX-RAILB-M4	Ball Bearing Rail Kit for HX-E-220M5SX Edge Nodes

Select an Optional Reversible Cable Management Arm

The reversible cable management arm mounts on either the right or left slide rails at the rear of the server and is used for cable management. Use [Table 17](#) to order a cable management arm.

Table 17 Cable Management Arm

Product ID (PID)	PID Description
HX-CMAF-M4	Reversible CMA for HX-E-220M5SX Edge Nodes

For more information about the tool-less rail kit and cable management arm, see the *Cisco UCS C220 M5 Installation and Service Guide* at this URL:

https://www.cisco.com/c/en/us/td/docs/unified_computing/ucs/c/hw/C220M5/install/C220M5.html



NOTE: If you plan to rackmount your HX-E-220M5SX Edge Node, you must order a tool-less rail kits. The same rail kits and CMA's are used for M4 and M5 servers.

STEP 14 SELECT OPERATION SYSTEM VERSION AND HYPERFLEX EDGE SUBSCRIPTION

Several operating system versions and HyperFlex Edge software subscriptions are available to choose from. HyperFlex comes conveniently pre-installed with the ESXi hypervisor of your choice, reducing the time needed to deploy a HyperFlex cluster on-site.

Select one VMware license from either section (VMware/VMware PAC Licenses) and one HyperFlex Edge software subscription license.

Select Operating systems and HyperFlex Software from [Table 18](#)

Table 18 Operating systems and HyperFlex Software

Product ID (PID)	PID Description
VMware	
HX-VSP-7-0-FND-D	Factory Installed vSphere SW 7.0 1-CPU Enduser provides License (HyperFlex Release 4.5(1a) and later)
HX-VSP-7-0-FND2-D	Factory Installed vSphere SW 7.0 2-CPU Enduser provides License (HyperFlex Release 4.5(1a) and later)
VMware PAC Licenses¹	
HX-VSP-ROBO1-STD	VMware vSphere 7.x ROBO Standard (25 VM pack)
HX-VSP-ROBO2-STD	VMware vSphere 7.x ROBO Standard (100 VM pack)
HX-VSP-ROBO3-STD	VMware vSphere 7.x ROBO Standard (500 VM pack)
HX-VSP-ROBO1-ADV	VMware vSphere 7.x ROBO Advanced (25 VM pack)
HX-VSP-ROBO2-ADV	VMware vSphere 7.x ROBO Advanced (100 VM pack)
HX-VSP-ROBO3-ADV	VMware vSphere 7.x ROBO Advanced (500 VM pack)
HX-VSP-ROBO1-ENT	VMware vSphere 7.x ROBO Enterprise (25 VM pack)
HX-VSP-ROBO2-ENT	VMware vSphere 7.x ROBO Enterprise (100 VM pack)
HX-VSP-ROBO3-ENT	VMware vSphere 7.x ROBO Enterprise (500 VM pack)
HX-VSP-EPL-1A	VMware vSphere 7 Ent Plus (1 CPU), 1-yr, Support Required Cisco
HX-VSP-EPL-3A	VMware vSphere 7 Ent Plus (1 CPU), 3-yr, Support Required Cisco
HX-VSP-EPL-5A	VMware vSphere 7 Ent Plus (1 CPU), 5-yr, Support Required Cisco
HX-VSP-STD-1A	VMware vSphere 7 Standard (1 CPU), 1-yr, Support Required Cisco
HX-VSP-STD-3A	VMware vSphere 7 Standard (1 CPU), 3-yr, Support Required Cisco
HX-VSP-STD-5A	VMware vSphere 7 Standard (1 CPU), 5-yr, Support Required Cisco
Guest Operating system²	

Table 18 Operating systems and HyperFlex Software

Microsoft Windows Server	
MSWS-19-DC16C-NS	Windows Server 2019 Data Center (16 Cores/Unlimited VMs) - No Cisco SVC
MSWS-19-ST16C-NS	Windows Server 2019 Standard (16 Cores/2 VMs) - No Cisco SVC
HX-MSWS-19-DC16C	Windows Server 2019 Data Center (16 Cores/Unlimited VMs)
HX-MSWS-19-ST16C	Windows Server 2019 Standard (16 Cores/2 VMs)

Notes:

1. Choose quantity of two when choosing PAC licensing for dual CPU systems.
2. Optional guest OS licenses that may be purchased to run on top of the hypervisor

STEP 15 SELECT HX DATA PLATFORM SOFTWARE

HyperFlex Data Platform Edition & Subscription Period options are available as follows. Select as desired from [Table 19](#)

Table 19 HX Data Platform Software

Product ID (PID)	PID Description
HXDP-E001-1YR to HXDP-E001-5YR	HyperFlex Data Platform Edge Advantage (1 to 5) Yr
HXDP-E-SLR	HyperFlex Data Platform Edge Advantage SLR 1 to 10 Years
HXDP-EP001-1YR to HXDP-EP001-5YR	HyperFlex Data Platform Edge Premier (1 to 5) Yr
HXDP-EP-SLR	HyperFlex Data Platform Edge Premier SLR 1 to 10 Years
HXDP-S001-1YR to HXDP-S001-5YR	HyperFlex Data Platform Datacenter Advantage (1 to 5) Yr
HXDP-S-SLR	HyperFlex Data Platform Datacenter Advantage SLR 1 to 10 Years

STEP 16 SELECT SERVICE and SUPPORT LEVEL

A variety of service options are available, as described in this section.

Smart Net Total Care (SNTC) for UCS

For support of the entire Unified Computing System, Cisco offers the Cisco Smart Net Total Care for UCS Service. This service provides expert software and hardware support to help sustain performance and high availability of the unified computing environment. Access to Cisco Technical Assistance Center (TAC) is provided around the clock, from anywhere in the world

For systems that include Unified Computing System Manager, the support service includes downloads of UCSM upgrades. The Cisco Smart Net Total Care for UCS Service includes flexible hardware replacement options, including replacement in as little as two hours. There is also access to Cisco's extensive online technical resources to help maintain optimal efficiency and uptime of the unified computing environment. For more information please refer to the following url: <http://www.cisco.com/c/en/us/services/technical/smart-net-total-care.html?stickynav=1>

You can choose a desired service listed in [Table 20](#).

Table 20 Cisco SNTC for UCS Service (PID HX-E-220M5SX)

Service SKU	Service Level GSP	On Site?	Description
CON-PREM-220CM5SX	C2P	Yes	SNTC 24X7X2OS
CON-UCSD8-220CM5SX	UCSD8	Yes	UC SUPP DR 24X7X2OS*
CON-C2PL-220CM5SX	C2PL	Yes	LL 24X7X2OS**
CON-OSP-220CM5SX	C4P	Yes	SNTC 24X7X4OS
CON-UCSD7-220CM5SX	UCSD7	Yes	UCS DR 24X7X4OS*
CON-C4PL-220CM5SX	C4PL	Yes	LL 24X7X4OS**
CON-USD7L-220CM5SX	USD7L	Yes	LLUCS HW DR 24X7X4OS***
CON-OSE-220CM5SX	C4S	Yes	SNTC 8X5X4OS
CON-UCSD6-220CM5SX	UCSD6	Yes	UC SUPP DR 8X5X4OS*
CON-SNCO-220CM5SX	SNCO	Yes	SNTC 8x7xNCDOS****
CON-OS-220CM5SX	CS	Yes	SNTC 8X5XNBDOS
CON-UCSD5-220CM5SX	UCSD5	Yes	UCS DR 8X5XNBDOS*
CON-S2P-220CM5SX	S2P	No	SNTC 24X7X2
CON-S2PL-220CM5SX	S2PL	No	LL 24X7X2**
CON-SNTP-220CM5SX	SNTP	No	SNTC 24X7X4
CON-SNTPL-220CM5SX	SNTPL	No	LL 24X7X4**
CON-SNTE-220CM5SX	SNTE	No	SNTC 8X5X4
CON-SNC-220CM5SX	SNC	No	SNTC 8x7xNCD****
CON-SNT-220CM5SX	SNT	No	SNTC 8X5XNBD
CON-SW-220CM5SX	SW	No	SNTC NO RMA

*Includes Drive Retention (see below for full description)

**Includes Local Language Support (see below for full description) - Only available in China and Japan

***Includes Local Language Support and Drive Retention - Only available in China and Japan

****Available in China Only

Smart Net Total Care with Onsite Troubleshooting Service

An enhanced offer over traditional Smart Net Total Care which provides onsite troubleshooting expertise to aid in the diagnostics and isolation of hardware issue within our customers' Cisco Hyper-Converged environment. It is delivered by a Cisco Certified field engineer (FE) in collaboration with remote TAC engineer and Virtual Internet working Support Engineer (VISE). You can choose a desired service listed in [Table 21](#)

Table 21 SNTC with UCS Onsite Troubleshooting Service (PID HX-E-220M5SX)

Service SKU	Service Level GSP	On Site?	Description
CON-OSPT-220CM5SX	OSPT	Yes	24X7X4OS Trblshtg
CON-OSPTD-220CM5SX	OSPTD	Yes	24X7X4OS TrblshtgDR*
CON-OSPTL-220CM5SX	OSPTL	Yes	24X7X4OS TrblshtgLL**
CON-OPTLD-220CM5SX	OPTLD	Yes	24X7X4OS TrblshtgLLD***

*Includes Drive Retention (see below for full description)

**Includes Local Language Support (see below for full description) – Only available in China and Japan

***Includes Local Language Support and Drive Retention – Only available in China and Japan

Solution Support

Solution Support includes both Cisco product support and solution-level support, resolving complex issues in multivendor environments, on average, 43% more quickly than product support alone. Solution Support is a critical element in data center administration, to help rapidly resolve any issue encountered, while maintaining performance, reliability, and return on investment.

This service centralizes support across your multivendor Cisco environment for both our products and solution partner products you've deployed in your ecosystem. Whether there is an issue with a Cisco or solution partner product, just call us. Our experts are the primary point of contact and own the case from first call to resolution. For more information please refer to the following url:

<http://www.cisco.com/c/en/us/services/technical/solution-support.html?stickynav=1>

You can choose a desired service listed in [Table 22](#)

Table 22 Solution Support Service (PID HX-E-220M5SX)

Service SKU	Service Level GSP	On Site?	Description
CON-SSC2P-220CM5SX	SSC2P	Yes	SOLN SUPP 24X7X2OS
CON-SSC4P-220CM5SX	SSC4P	Yes	SOLN SUPP 24X7X4OS
CON-SSC4S-220CM5SX	SSC4S	Yes	SOLN SUPP 8X5X4OS
CON-SSCS-220CM5SX	SSCS	Yes	SOLN SUPP 8X5XNBDOS

Table 22 Solution Support Service (PID HX-E-220M5SX)

CON-SSDR7-220CM5SX	SSDR7	Yes	SSPT DR 24X7X40S*
CON-SSDR5-220CM5SX	SSDR5	Yes	SSPT DR 8X5XNBDOS*
CON-SSS2P-220CM5SX	SSS2P	No	SOLN SUPP 24X7X2
CON-SSSNP-220CM5SX	SSSNP	No	SOLN SUPP 24X7X4
CON-SSSNE-220CM5SX	SSSNE	No	SOLN SUPP 8X5X4
CON-SSSNC-220CM5SX	SSSNC	No	SOLN SUPP NCD**
CON-SSSNT-220CM5SX	SSSNT	No	SOLN SUPP 8X5XNBD

Includes Drive Retention (see below for description)

**Available in China only

Partner Support Service for UCS

Cisco Partner Support Service (PSS) is a Cisco Collaborative Services service offering that is designed for partners to deliver their own branded support and managed services to enterprise customers. Cisco PSS provides partners with access to Cisco's support infrastructure and assets to help them:

- Expand their service portfolios to support the most complex network environments
- Lower delivery costs
- Deliver services that increase customer loyalty

PSS options enable eligible Cisco partners to develop and consistently deliver high-value technical support that capitalizes on Cisco intellectual assets. This helps partners to realize higher margins and expand their practice.

PSS is available to all Cisco PSS partners.

PSS provides hardware and software support, including triage support for third party software, backed by Cisco technical resources and level three support. You can choose a desired service listed in [Table 23](#).

Table 23 PSS (PID HX-E-220M5SX)

Service SKU	Service Level GSP	On Site?	Description
CON-PSJ8-220CM5SX	PSJ8	Yes	UCS PSS 24X7X2 OS
CON-PSJ7-220CM5SX	PSJ7	Yes	UCS PSS 24X7X4 OS
CON-PSJD7-220CM5SX	PSJD7	Yes	UCS PSS 24X7X4 DR*
CON-PSJ6-220CM5SX	PSJ6	Yes	UCS PSS 8X5X4 OS
CON-PSJD6-220CM5SX	PSJD6	Yes	UCS PSS 8X5X4 DR*
CON-PSJ4-220CM5SX	PSJ4	No	UCS SUPP PSS 24X7X2
CON-PSJ3-220CM5SX	PSJ3	No	UCS SUPP PSS 24X7X4
CON-PSJ2-220CM5SX	PSJ2	No	UCS SUPP PSS 8X5X4

Table 23 PSS (PID HX-E-220M5SX)

CON-PSJ1-220CM5SX	PSJ1	No	UCS SUPP PSS 8X5XNBD
*Includes Drive Retention (see below for description)			

Combined Support Service

Combined Services makes it easier to purchase and manage required services under one contract. The more benefits you realize from the Cisco HyperFlex System, the more important the technology becomes to your business. These services allow you to:

- Optimize the uptime, performance, and efficiency of your HyperFlex System
- Protect your vital business applications by rapidly identifying and addressing issues
- Strengthen in-house expertise through knowledge transfer and mentoring
- Improve operational efficiency by allowing HyperFlex experts to augment your internal staff resources
- Enhance business agility by diagnosing potential issues before they affect your operations

You can choose a desired service listed in [Table 24](#)

Table 24 Combined Support Service (PID HX-E-220M5SX)

Service SKU	Service Level GSP	On Site?	Description
CON-NCF2P-220CM5SX	NCF2P	Yes	CMB SVC 24X7X2OS
CON-NCF4P-220CM5SX	NCF4P	Yes	CMB SVC 24X7X4OS
CON-NCF4S-220CM5SX	NCF4S	Yes	CMB SVC 8X5X4OS
CON-NCFCS-220CM5SX	NCFCS	Yes	CMB SVC 8X5XNBDOS
CON-NCF2-220CM5SX	NCF2	No	CMB SVC 24X7X2
CON-NCFP-220CM5SX	NCFP	No	CMB SVC 24X7X4
CON-NCFE-220CM5SX	NCFE	No	CMB SVC 8X5X4
CON-NCFT-220CM5SX	NCFT	No	CMB SVC 8X5XNBD
CON-NCFW-220CM5SX	NCFW	No	CMB SVC SW

UCS Drive Retention Service

With the Cisco Drive Retention Service, you can obtain a new disk drive in exchange for a faulty drive without returning the faulty drive.

Sophisticated data recovery techniques have made classified, proprietary, and confidential information vulnerable, even on malfunctioning disk drives. The Drive Retention service enables you to retain your drives and ensures that the sensitive data on those drives is not compromised, which reduces the risk of any potential liabilities. This service also enables you to comply with regulatory, local, and federal requirements.

If your company has a need to control confidential, classified, sensitive, or proprietary data, you might want to consider one of the Drive Retention Services listed in the above tables (where available)



NOTE: Cisco does not offer a certified drive destruction service as part of this service.

Local Language Technical Support for UCS

Where available, and subject to an additional fee, local language support for calls on all assigned severity levels may be available for specific product(s) - see tables above.

For a complete listing of available services for Cisco HyperFlex System, see the following URL:
<https://www.cisco.com/c/en/us/services/technical.html?stickynav=1>

SUPPLEMENTAL MATERIAL

Supported Network Topologies for HyperFlex Edge 2 Node Deployments

Cisco HyperFlex Edge offers both a 1 Gigabit Ethernet (GE) and a 10/25GE installation option. Both topologies support single top-of-rack (ToR) and dual ToR switch options for ultimate network flexibility and redundancy.

Consider the following when determining the best topology for your cluster:

- Cisco highly recommends the 10/25GE topology for higher performance and future node expansion capabilities.
- The 1GE topology is reserved for clusters that will never require node expansion, and instances where the ToR switch does not have 10GE or 25GE ports available.



NOTE: A network topology is chosen during initial deployment and cannot be changed or upgraded without a full reinstallation. Choose your network topology carefully and with future needs in mind.

Below is a summary of the supported topologies, refer to the [Cisco HyperFlex Edge Deployment Guide, Pre-installation Checklist chapter](#), for full details.

10/25 Gigabit Ethernet Topology

The 10/25 Gigabit Ethernet (GE) switch topology provides a fully redundant design that protects against switch (if using dual or stacked switches), link and port failures. The 10/25GE switch may be one or two standalone switches or may be formed as a switch stack.

To deploy this topology, select HX-E-TOP01 in [Step 6](#).

Figure 5 Physical cabling for the 10/25GE Dual Switch topology. Detailed diagrams for other topologies can be found in the pre-installation checklist.

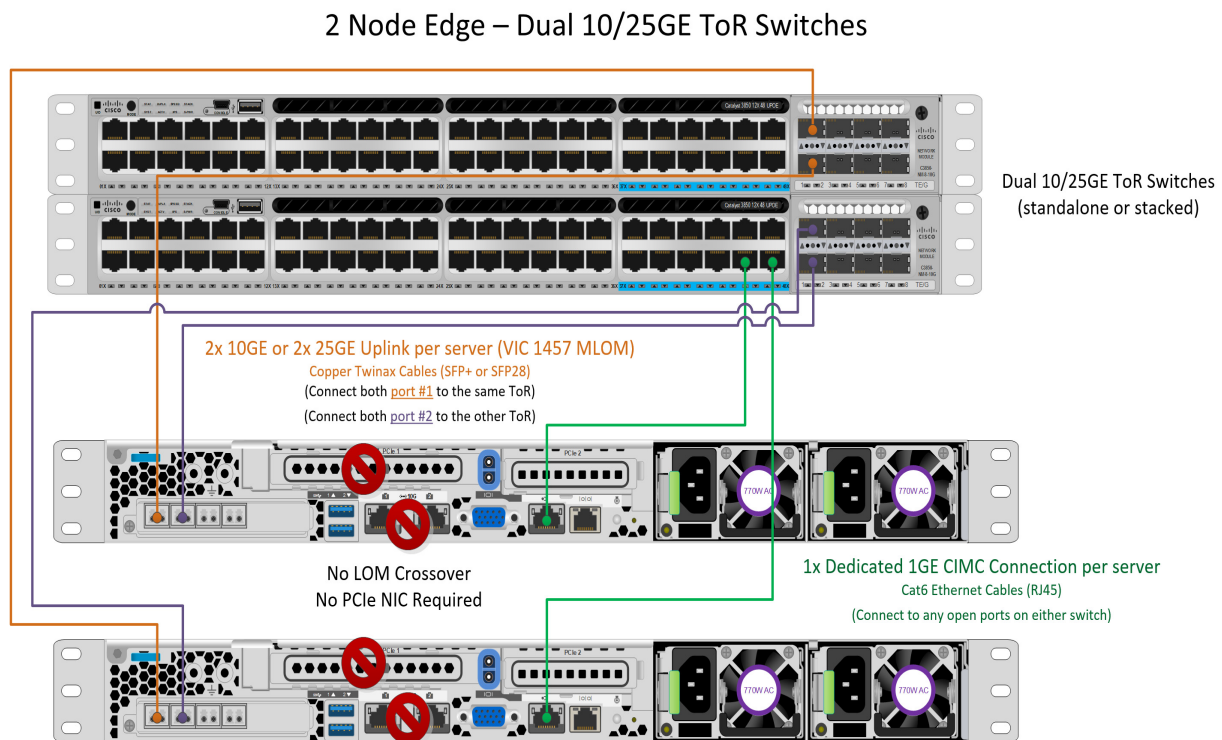

1 Gigabit Ethernet Topology

The 1 Gigabit Ethernet (GE) switch topology provides a fully redundant design that protects against switch (if using dual or stacked switches), link and port failures. The 1GE switch may be one or two standalone switches or may be formed as a switch stack.

To deploy this topology, select HX-E-TOPO2 in [Step 6](#).

Figure 6 Physical cabling for the 1GE Dual Switch topology. Detailed diagrams for other topologies can be found in the pre-installation checklist.

2 Node Edge – Dual 1GE ToR Switches

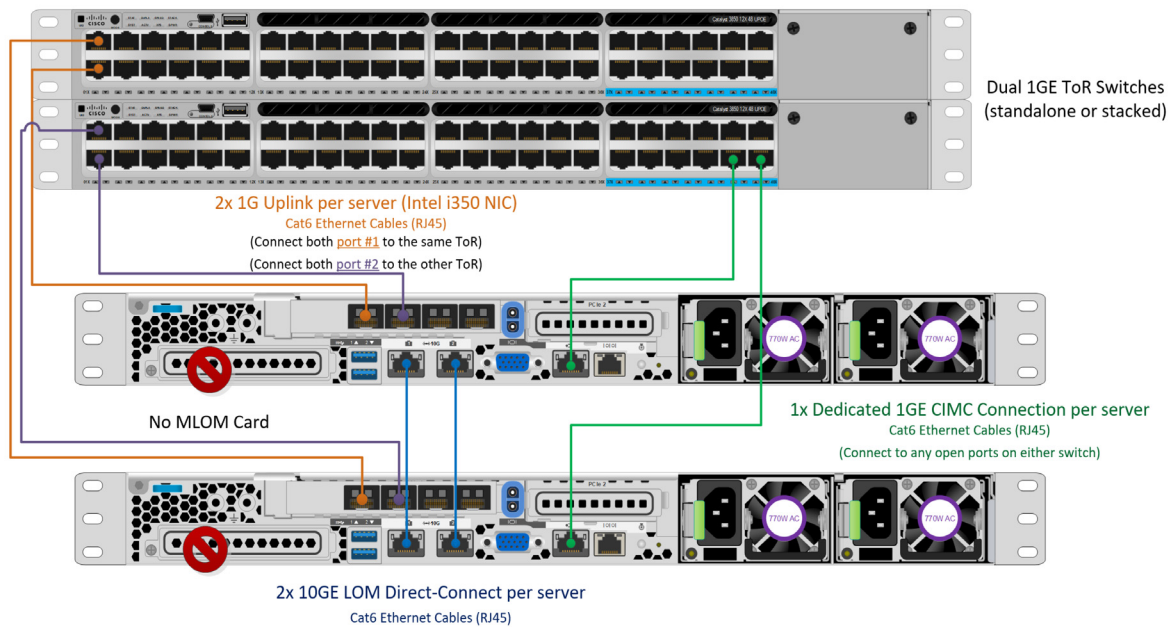

Supported Network Topologies for HyperFlex Edge 3 and 4 Node Deployments

Cisco HyperFlex Edge offers both a 1 Gigabit Ethernet (GE) and a 10/25GE installation option. Both topologies support single top-of-rack (ToR) and dual ToR switch options for ultimate network flexibility and redundancy.

Consider the following when determining the best topology for your cluster:

- Cisco highly recommends the 10/25GE topology for higher performance and future node expansion capabilities.
- The 1GE topology is reserved for clusters that will never require node expansion, and instances where the ToR switch does not have 10GE or 25GE ports available.



NOTE: A network topology is chosen during initial deployment and cannot be changed or upgraded without a full reinstallation. Choose your network topology carefully and with future needs in mind.

Below is a summary of the supported topologies, refer to the [Cisco HyperFlex Edge Deployment Guide, Pre-installation Checklist chapter](#), for full details.

10/25 Gigabit Ethernet Topology

The 10/25 Gigabit Ethernet (GE) switch topology provides a fully redundant design that protects against switch (if using dual or stacked switches), link and port failures. The 10/25GE switch may be one or two standalone switches or may be formed as a switch stack.

To deploy this topology, select HX-E-TOP01 in **Step 6**.

Figure 7 Physical cabling for the 10/25GE Dual Switch topology. Detailed diagrams for other topologies can be found in the pre-installation checklist.

3 & 4 Node Edge – Dual 10/25GE ToR Switches

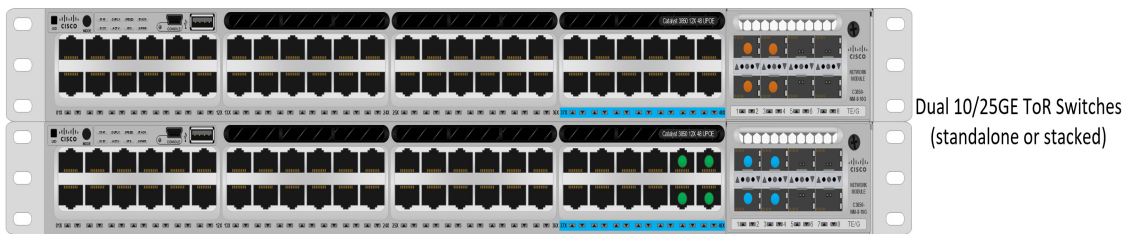

2x 10GE or 2x 25GE Uplink per server (VIC 1457 MLOM)

Copper Twinax Cables (SFP+ or SFP28)

(Connect all [port #1](#) to the same ToR)

(Connect all [port #2](#) to the other ToR)

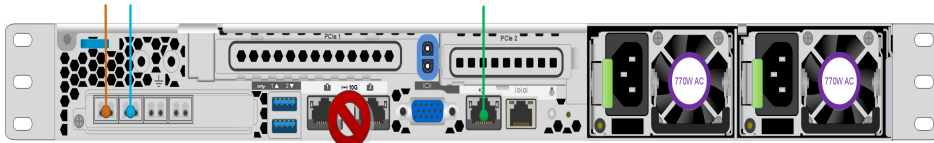

x3 or x4

1x Dedicated 1GE CIMC Connection per server

Cat6 Ethernet Cables (RJ45)

(Connect to any open port on either switch)

1 Gigabit Ethernet Dual Switch Topology

Dual switch configuration provides a slightly more complex topology with full redundancy that protects against: switch failure, link and port failure, and LOM/PCIe NIC HW failures. It requires two switches that may be standalone or stacked, and four 1GbE ports and one additional PCIe NIC per server. Trunk ports are the only supported network port configuration.

Figure 8 Physical cabling for the 1GE Dual Switch topology. Detailed diagrams for other topologies can be found in the pre-installation checklist.

3 & 4 Node Edge – Dual 1GE ToR Switches

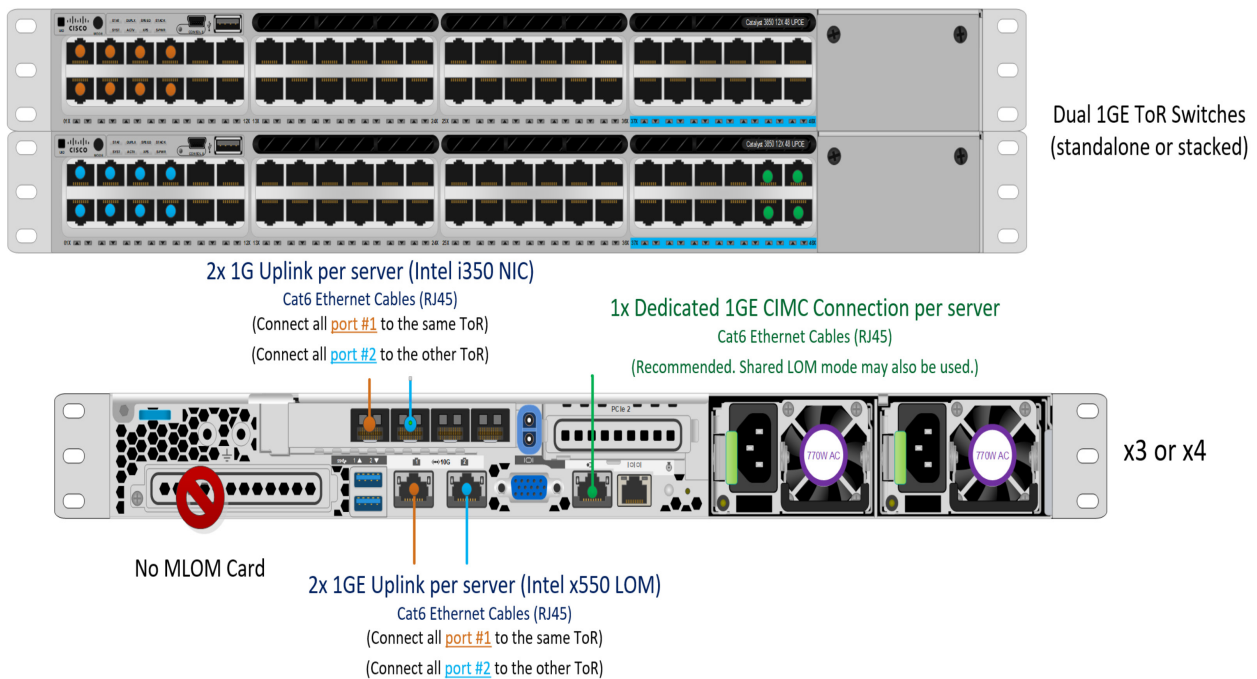

1 Gigabit Ethernet Single Switch Topology

Single switch configuration provides a simple topology requiring only a single switch, and two 1GbE ports per server. Link or switch redundancy is not provided. Access ports and trunk ports are the two supported network port configurations.

Figure 9 Physical cabling for the 1GE Single Switch topology. Detailed diagrams for other topologies can be found in the pre-installation checklist.

3 & 4 Node Edge – Single 1GE ToR Switch

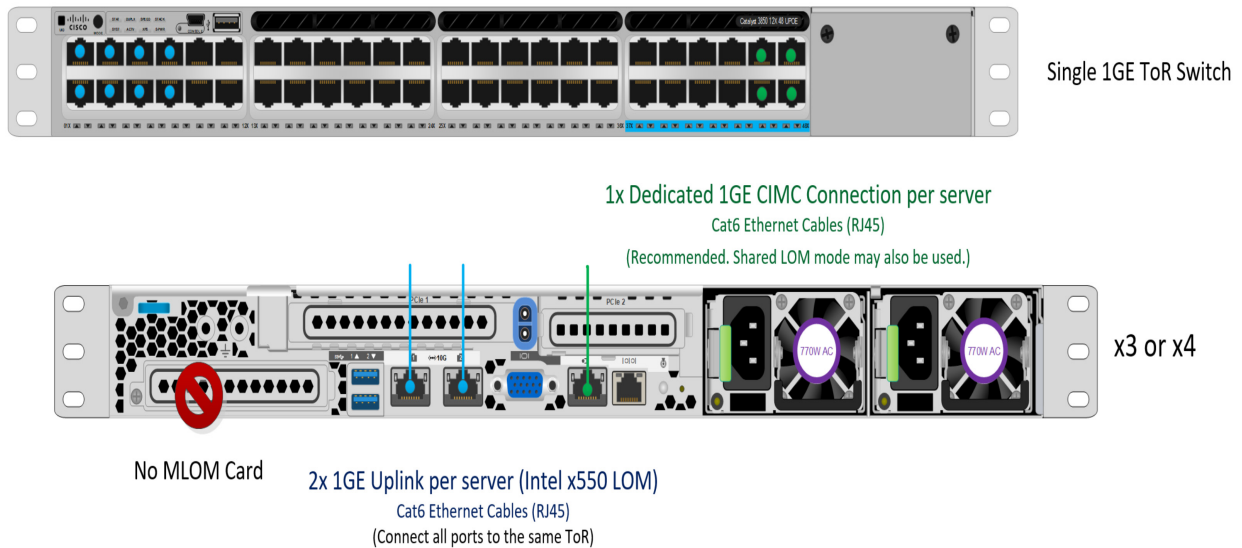

CHASSIS

An internal view of the HX-E-220M5SX Edge Node chassis with the top cover removed is shown in [Figure 10](#).

Figure 10 HX-E-220M5SX Edge With Top Cover Off

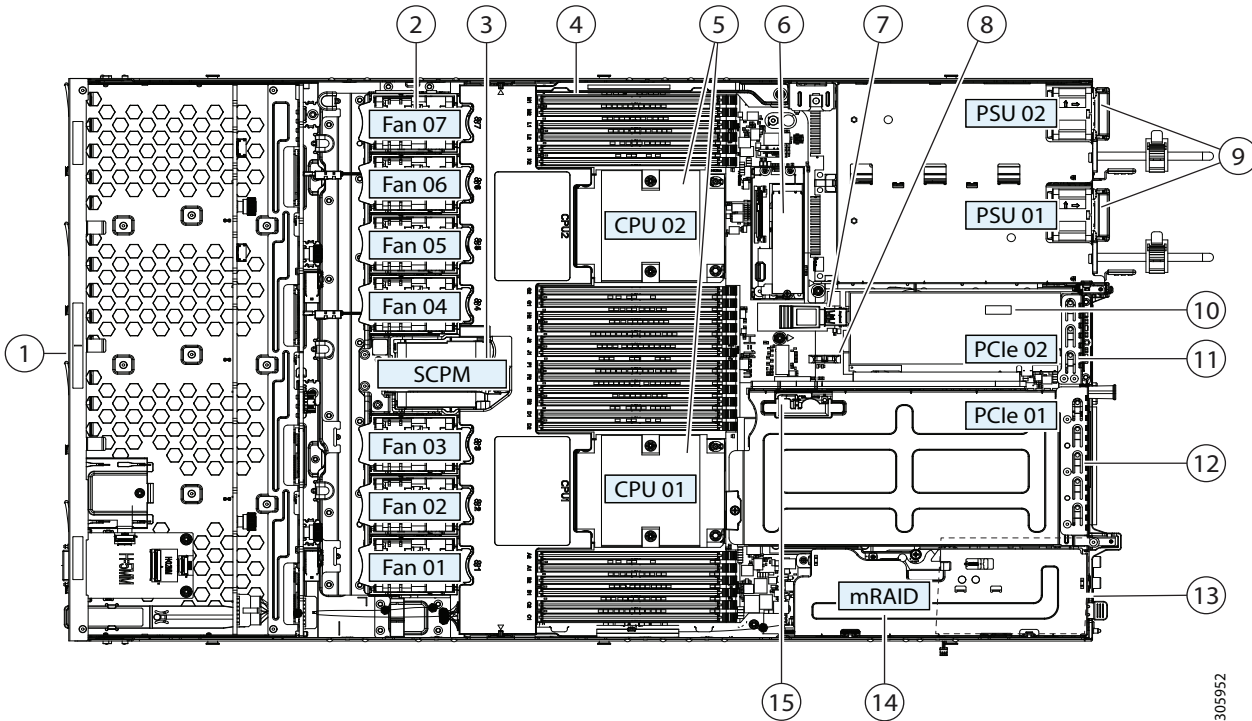

1	Drive bays 1-10 are hot swappable	9	Power supplies (Hot-swappable when redundant as 1+1)
2	Cooling fan modules (seven)	10	Trusted platform module (TPM) socket on motherboard (not visible in this view)
3	N/A	11	PCIe slot 2 (half-height, x16)
4	DIMM sockets on motherboard (up to 12 per CPU; total 24)	12	PCIe slot 1 (full-height, x16); includes socket for Micro-SD card
5	CPUs and heatsinks (up to two)	13	Modular LOM (mLOM) card bay on chassis floor (x16) (not visible in this view)
6	Mini storage module connector For M.2 module with SATA M.2 SSD slots	14	Cisco 12 Gbps Modular SAS HBA controller card
7	Internal USB 3.0 port on motherboard	15	Micro-SD card socket on PCIe riser 1
8	RTC battery vertical socket on motherboard	-	-

Serial Port Details

The pinout details of the rear RJ-45 serial port connector are shown in [Figure 11](#).

Figure 11 Serial Port (Female RJ-45 Connector) Pinout

Serial Port (RJ-45 Female Connector)

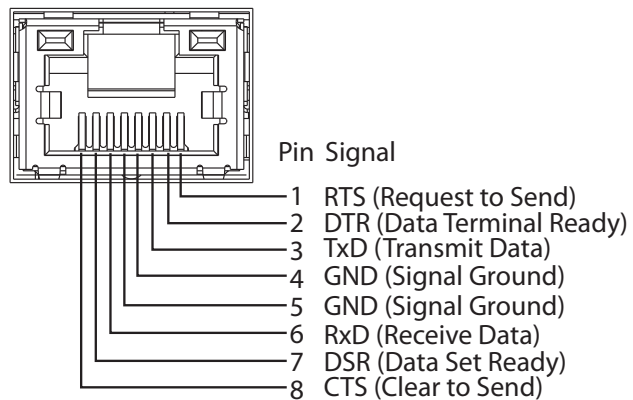

Upgrade and Servicing-Related Parts

This section lists the upgrade and servicing-related parts you may need during the life of your system. Some of these parts are configured with every system, and some may be ordered when needed or may be ordered and kept on hand as spares for future use.

Table 25 Upgrade and Servicing-related Parts for HX-E-220M5SX Edge Server

Spare Product ID (PID)	Description
UCSC-HS-C220M5=	Heat sink for UCS C220 M5 rack servers 150W CPUs & below
UCSC-HS2-C220M5=	Heat sink for UCS C220 M5 rack servers CPUs above 150W
UCS-CPUAT=	CPU Assembly Tool for M5 Servers
UCS-CPU-TIM=	Single CPU thermal interface material syringe for M5 server HS seal
UCSX-HSCK=	UCS Processor Heat Sink Cleaning Kit For Replacement of CPU
UCS-M5-CPU-CAR=	UCS M5 CPU Carrier
CBL-NVME-C220FF=	C220 M5L/M5S PCIe SSD cable (1) for SFF & LFF chassis
UCSC-SATA-KIT-M5=	C220 M5 (2) SATA/SW RAID cables, 1U riser & interposer, for up to 8-drives
UCSC-SATAIN-220M5=	C220 M5 (8-drive) SATA Interposer board
UCSC-XRAIDR-220M5=	Riser to support SATA, MRAID for C220 M5 servers
UCSC-BBLKD-S2=	C-Series M5 SFF drive blanking panel
UCSC-PCIF-01H=	PCIe Low Profile blanking panel for UCS C-Series Server
UCSC-PCIF-01F=	PCIe Full Height blanking panel for UCS C-Series Server
UCSC-MLOM-BLK=	MLOM Blanking Panel
UCSC-RAILF-M4=	Friction Rail Kit for C220 M4 rack servers
UCSC-CMAF-M4=	Reversible CMA for C220 M4 friction & ball bearing rail kits
UCSC-RAILB-M4=	Ball Bearing Rail Kit for C220 M4 and C240 M4 rack servers
UCSC-BZL-C220M5=	C220 M5 Security Bezel
UCSC-FAN-C220M5=	C220 M5 Fan Module (one)
N20-BKVM=	KVM cable for Server console port
UCSC-PSU-BLKP1U=	Power Supply Blanking Panel for C220 M5 and C240 M5 servers
UCS-MSTOR-SD=	Mini Storage Carrier for SD (holds up to 2)
UCS-MSTOR-M2=	Mini Storage Carrier for M.2 SATA (max one drive supported)

KVM CABLE

The KVM cable provides a connection into the server, providing a DB9 serial connector, a VGA connector for a monitor, and dual USB ports for a keyboard and mouse. With this cable, you can create a direct connection to the operating system and the BIOS running on the server.

The KVM cable ordering information is listed in [Table 26](#).

Table 26 KVM Cable

Product ID (PID)	PID Description
N20-BKVM=	KVM cable for UCS Server console port

Figure 12 KVM Cable

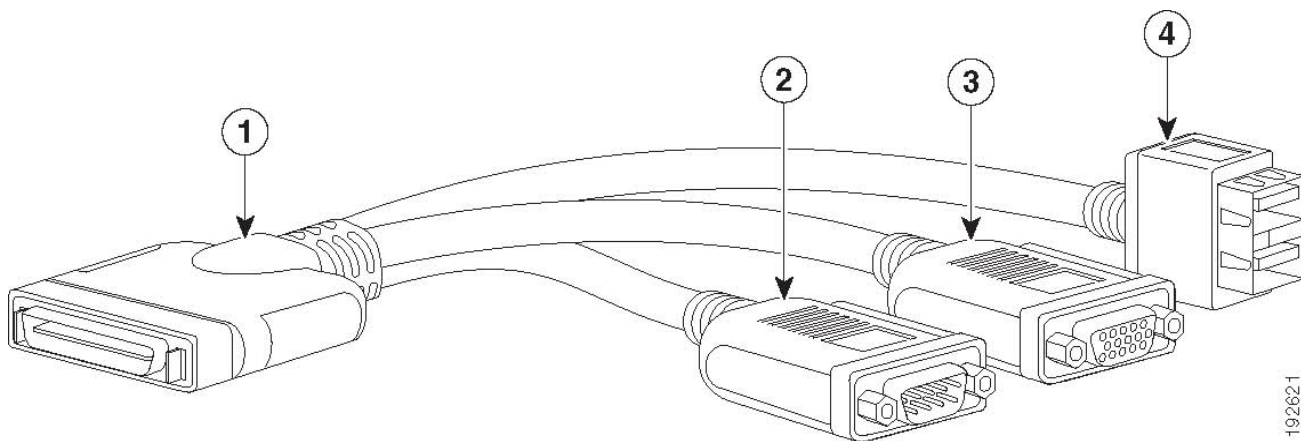

192621

1	Connector (to server front panel)	3	VGA connector (for a monitor)
2	DB-9 serial connector	4	Two-port USB connector (for a mouse and keyboard)

DISCONTINUED EOL PRODUCTS

Below is the list of parts were previously available for this product and are no longer sold. Please refer to the EOL Bulletin Links via the [Table 27](#) below to determine if still supported.

Table 27 EOL Products

EOS option PID	Description	EOL bulletin link
DRIVES		
Enterprise Value SSDs		
HX-SD240G61X-EV	240GB 2.5 inch Enterprise Value 6G SATA SSD	https://www.cisco.com/c/en/us/products/collateral/servers-unified-computing/ucs-b-series-blade-servers/eos-eol-notice-c51-742066.html
HX-SD800G123X-EP	800GB 2.5in Enterprise Performance 12G SAS SSD(3X endurance)	https://www.cisco.com/c/en/us/products/collateral/hyperconverged-infrastructure/hyperflex-hx-series/eos-eol-notice-c51-2451489.html
CPU		
HX-CPU-I8280M	Intel 8280M 2.7GHz/205W 28C/38.50MB 3DX DDR4 2TB 2933 MHz	https://www.cisco.com/c/en/us/products/collateral/servers-unified-computing/ucs-c-series-rack-servers/eos-eol-notice-c51-743832.html
HX-CPU-I8276M	Intel 8276M 2.2GHz/165W 28C/38.50MB 3DX DDR4 2TB 2933 MHz	https://www.cisco.com/c/en/us/products/collateral/servers-unified-computing/ucs-c-series-rack-servers/eos-eol-notice-c51-743832.html
HX-CPU-I8260M	Intel 8260M 2.4GHz/165W 24C/35.75MB 3DX DDR4 2TB 2933 MHz	https://www.cisco.com/c/en/us/products/collateral/servers-unified-computing/ucs-c-series-rack-servers/eos-eol-notice-c51-743832.html
HX-CPU-I6240M	Intel 6240M 2.6GHz/150W 18C/24.75MB 3DX DDR4 2TB 2933 MHz	https://www.cisco.com/c/en/us/products/collateral/servers-unified-computing/ucs-c-series-rack-servers/eos-eol-notice-c51-743832.html
HX-CPU-I6238M	Intel 6238M 2.1GHz/140W 22C/30.25MB 3DX DDR4 2TB 2933 MHz	https://www.cisco.com/c/en/us/products/collateral/servers-unified-computing/ucs-c-series-rack-servers/eos-eol-notice-c51-743832.html
HX-CPU-I5215M	Intel 5215M 2.5GHz/85W 10C/13.75MB 3DX DDR4 2TB 2666MHz	https://www.cisco.com/c/en/us/products/collateral/servers-unified-computing/ucs-c-series-rack-servers/eos-eol-notice-c51-743832.html
HX-CPU-8180M	2.5 GHz 8180M/205W 28C/38.50MB Cache/DDR4 2666MHz	https://www.cisco.com/c/en/us/products/collateral/servers-unified-computing/ucs-c-series-rack-servers/eos-eol-notice-c51-744580.html
HX-CPU-8176M	2.1 GHz 8176M/165W 28C/38.50MB Cache/DDR4 2666MHz	https://www.cisco.com/c/en/us/products/collateral/servers-unified-computing/ucs-c-series-rack-servers/eos-eol-notice-c51-744580.html
HX-CPU-8170M	2.1 GHz 8170M/165W 26C/35.75MB Cache/DDR4 2666MHz	https://www.cisco.com/c/en/us/products/collateral/servers-unified-computing/ucs-c-series-rack-servers/eos-eol-notice-c51-744580.html
HX-CPU-8160M	2.1 GHz 8160M/150W 24C/33MB Cache/DDR4 2666MHz	https://www.cisco.com/c/en/us/products/collateral/servers-unified-computing/ucs-c-series-rack-servers/eos-eol-notice-c51-744580.html

Table 27 EOL Products

EOS option PID	Description	EOL bulletin link
HX-CPU-8180	2.5 GHz 8180/205W 28C/38.50MB Cache/DDR4 2666MHz	https://www.cisco.com/c/en/us/products/collateral/servers-unified-computing/ucs-c-series-rack-servers/eos-eol-notice-c51-744580.html
HX-CPU-8176	2.1 GHz 8176/165W 28C/38.50MB Cache/DDR4 2666MHz	https://www.cisco.com/c/en/us/products/collateral/servers-unified-computing/ucs-c-series-rack-servers/eos-eol-notice-c51-744580.html
HX-CPU-8170	2.1 GHz 8170/165W 26C/35.75MB Cache/DDR4 2666MHz	https://www.cisco.com/c/en/us/products/collateral/servers-unified-computing/ucs-c-series-rack-servers/eos-eol-notice-c51-744580.html
HX-CPU-8168	2.7 GHz 8168/205W 24C/33MB Cache/DDR4 2666MHz	https://www.cisco.com/c/en/us/products/collateral/servers-unified-computing/ucs-c-series-rack-servers/eos-eol-notice-c51-744580.html
HX-CPU-8164	2.0 GHz 8164/150W 26C/35.75MB Cache/DDR4 2666MHz	https://www.cisco.com/c/en/us/products/collateral/servers-unified-computing/ucs-c-series-rack-servers/eos-eol-notice-c51-744580.html
HX-CPU-8160	2.1 GHz 8160/150W 24C/33MB Cache/DDR4 2666MHz	https://www.cisco.com/c/en/us/products/collateral/servers-unified-computing/ucs-c-series-rack-servers/eos-eol-notice-c51-744580.html
HX-CPU-8158	3.0 GHz 8158/150W 12C/24.75MB Cache/DDR4 2666MHz	https://www.cisco.com/c/en/us/products/collateral/servers-unified-computing/ucs-c-series-rack-servers/eos-eol-notice-c51-744580.html
HX-CPU-8153	2.0 GHz 8153/125W 16C/22MB Cache/DDR4 2666MHz	https://www.cisco.com/c/en/us/products/collateral/servers-unified-computing/ucs-c-series-rack-servers/eos-eol-notice-c51-744580.html
HX-CPU-6142M	2.6 GHz 6142M/150W 16C/22MB Cache/DDR4 2666MHz	https://www.cisco.com/c/en/us/products/collateral/servers-unified-computing/ucs-c-series-rack-servers/eos-eol-notice-c51-744580.html
HX-CPU-6140M	2.3 GHz 6140M/140W 18C/24.75MB Cache/DDR4 2666MHz	https://www.cisco.com/c/en/us/products/collateral/servers-unified-computing/ucs-c-series-rack-servers/eos-eol-notice-c51-744580.html
HX-CPU-6134M	3.2 GHz 6134M/130W 8C/24.75MB Cache/DDR4 2666MHz	https://www.cisco.com/c/en/us/products/collateral/servers-unified-computing/ucs-c-series-rack-servers/eos-eol-notice-c51-744580.html
HX-CPU-6154	3.0 GHz 6154/200W 18C/24.75MB Cache/DDR4 2666MHz	https://www.cisco.com/c/en/us/products/collateral/servers-unified-computing/ucs-c-series-rack-servers/eos-eol-notice-c51-744580.html
HX-CPU-6152	2.1 GHz 6152/140W 22C/30.25MB Cache/DDR4 2666MHz	https://www.cisco.com/c/en/us/products/collateral/servers-unified-computing/ucs-c-series-rack-servers/eos-eol-notice-c51-744580.html
HX-CPU-6150	2.7 GHz 6150/165W 18C/24.75MB Cache/DDR4 2666MHz	https://www.cisco.com/c/en/us/products/collateral/servers-unified-computing/ucs-c-series-rack-servers/eos-eol-notice-c51-744580.html
HX-CPU-6148	2.4 GHz 6148/150W 20C/27.50MB Cache/DDR4 2666MHz	https://www.cisco.com/c/en/us/products/collateral/servers-unified-computing/ucs-c-series-rack-servers/eos-eol-notice-c51-744580.html
HX-CPU-6144	3.5 GHz 6144/150W 8C/24.75MB Cache/DDR4 2666MHz	https://www.cisco.com/c/en/us/products/collateral/servers-unified-computing/ucs-c-series-rack-servers/eos-eol-notice-c51-744580.html

Table 27 EOL Products

EOS option PID	Description	EOL bulletin link
HX-CPU-6142	2.6 GHz 6142/150W 16C/22MB Cache/DDR4 2666MHz	https://www.cisco.com/c/en/us/products/collateral/servers-unified-computing/ucs-c-series-rack-servers/eos-eol-notice-c51-744580.html
HX-CPU-6140	2.3 GHz 6140/140W 18C/24.75MB Cache/DDR4 2666MHz	https://www.cisco.com/c/en/us/products/collateral/servers-unified-computing/ucs-c-series-rack-servers/eos-eol-notice-c51-744580.html
HX-CPU-6146	3.2 GHz 6146/165W 12C/24.75MB Cache/DDR4 2666MHz	https://www.cisco.com/c/en/us/products/collateral/servers-unified-computing/ucs-c-series-rack-servers/eos-eol-notice-c51-744580.html
HX-CPU-6138	2.0 GHz 6138/125W 20C/27.50MB Cache/DDR4 2666MHz	https://www.cisco.com/c/en/us/products/collateral/servers-unified-computing/ucs-c-series-rack-servers/eos-eol-notice-c51-744580.html
HX-CPU-6136	3.0 GHz 6136/150W 12C/24.75MB Cache/DDR4 2666MHz	https://www.cisco.com/c/en/us/products/collateral/servers-unified-computing/ucs-c-series-rack-servers/eos-eol-notice-c51-744580.html
HX-CPU-6134	3.2 GHz 6134/130W 8C/24.75MB Cache/DDR4 2666MHz	https://www.cisco.com/c/en/us/products/collateral/servers-unified-computing/ucs-c-series-rack-servers/eos-eol-notice-c51-744580.html
HX-CPU-6132	2.6 GHz 6132/140W 14C/19.25MB Cache/DDR4 2666MHz	https://www.cisco.com/c/en/us/products/collateral/servers-unified-computing/ucs-c-series-rack-servers/eos-eol-notice-c51-744580.html
HX-CPU-6130	2.1 GHz 6130/125W 16C/22MB Cache/DDR4 2666MHz	https://www.cisco.com/c/en/us/products/collateral/servers-unified-computing/ucs-c-series-rack-servers/eos-eol-notice-c51-744580.html
HX-CPU-6126	2.6 GHz 6126/125W 12C/19.25MB Cache/DDR4 2666MHz	https://www.cisco.com/c/en/us/products/collateral/servers-unified-computing/ucs-c-series-rack-servers/eos-eol-notice-c51-744580.html
HX-CPU-5120	2.2 GHz 5120/105W 14C/19.25MB Cache/DDR4 2400MHz	https://www.cisco.com/c/en/us/products/collateral/servers-unified-computing/ucs-c-series-rack-servers/eos-eol-notice-c51-744580.html
HX-CPU-5118	2.3 GHz 5118/105W 12C/16.50MB Cache/DDR4 2400MHz	https://www.cisco.com/c/en/us/products/collateral/servers-unified-computing/ucs-c-series-rack-servers/eos-eol-notice-c51-744580.html
HX-CPU-5117	2.0 GHz 5117/105W 14C/19.25MB Cache/DDR4 2400MHz	https://www.cisco.com/c/en/us/products/collateral/servers-unified-computing/ucs-c-series-rack-servers/eos-eol-notice-c51-744580.html
HX-CPU-5115	2.4 GHz 5115/85W 10C/13.75MB Cache/DDR4 2400MHz	https://www.cisco.com/c/en/us/products/collateral/servers-unified-computing/ucs-c-series-rack-servers/eos-eol-notice-c51-744580.html
HX-CPU-4116	2.1 GHz 4116/85W 12C/16.50MB Cache/DDR4 2400MHz	https://www.cisco.com/c/en/us/products/collateral/servers-unified-computing/ucs-c-series-rack-servers/eos-eol-notice-c51-744580.html
HX-CPU-4114	2.2 GHz 4114/85W 10C/13.75MB Cache/DDR4 2400MHz	https://www.cisco.com/c/en/us/products/collateral/servers-unified-computing/ucs-c-series-rack-servers/eos-eol-notice-c51-744580.html
HX-CPU-4110	2.1 GHz 4110/85W 8C/11MB Cache/DDR4 2400MHz	https://www.cisco.com/c/en/us/products/collateral/servers-unified-computing/ucs-c-series-rack-servers/eos-eol-notice-c51-744580.html

Table 27 EOL Products

EOS option PID	Description	EOL bulletin link
HX-CPU-4108	1.8 GHz 4108/85W 8C/11MB Cache/DDR4 2400MHz	https://www.cisco.com/c/en/us/products/collateral/servers-unified-computing/ucs-c-series-rack-servers/eos-eol-notice-c51-744580.html
HX-CPU-3106	1.7 GHz 3106/85W 8C/11MB Cache/DDR4 2133MHz	https://www.cisco.com/c/en/us/products/collateral/servers-unified-computing/ucs-c-series-rack-servers/eos-eol-notice-c51-744580.html
Memory		
HX-MR-128G8RS-H	128 GB DDR4-2666-MHz TSV-RDIMM/8R/x4	https://www.cisco.com/c/en/us/products/collateral/servers-unified-computing/ucs-c-series-rack-servers/eos-eol-notice-c51-2412151.html
HX-ML-X64G4RS-H	64 GB DDR4-2666-MHz LRDIMM/4R/x4	https://www.cisco.com/c/en/us/products/collateral/servers-unified-computing/ucs-c-series-rack-servers/eos-eol-notice-c51-2412151.html
HX-MR-X32G2RS-H	32 GB DDR4-2666-MHz RDIMM/2R/x4	https://www.cisco.com/c/en/us/products/collateral/servers-unified-computing/ucs-c-series-rack-servers/eos-eol-notice-c51-2412151.html
HX-MR-X16G1RS-H	16 GB DDR4-2666-MHz RDIMM/1R/x4	https://www.cisco.com/c/en/us/products/collateral/servers-unified-computing/ucs-c-series-rack-servers/eos-eol-notice-c51-2412151.html
HX-MR-X16G1RT-H	16GB DDR4-2933MHz RDIMM 1Rx4 (8Gb)/1.2v	https://www.cisco.com/c/en/us/products/collateral/servers-unified-computing/ucs-c-series-rack-servers/ucs-hyperflex-accessories-eol14611.html
HX-MR-X32G2RT-H	32GB DDR4-2933MHz RDIMM 2Rx4 (8Gb)/1.2v	https://www.cisco.com/c/en/us/products/collateral/servers-unified-computing/ucs-c-series-rack-servers/ucs-hyperflex-accessories-eol14611.html
HX-MR-X64G2RT-H	64GB DDR4-2933MHz RDIMM 2Rx4 (16Gb)/1.2v	https://www.cisco.com/c/en/us/products/collateral/servers-unified-computing/ucs-c-series-rack-servers/ucs-hyperflex-accessories-eol14611.html
HX-ML-X64G4RT-H	64GB DDR4-2933MHz LRDIMM 4Rx4 (8Gb)/1.2v	https://www.cisco.com/c/en/us/products/collateral/servers-unified-computing/ucs-c-series-rack-servers/ucs-hyperflex-accessories-eol14611.html
HX-ML-128G4RT-H	128GB DDR4-2933MHz LRDIMM 4Rx4 (16Gb)/1.2v	https://www.cisco.com/c/en/us/products/collateral/servers-unified-computing/ucs-c-series-rack-servers/ucs-hyperflex-accessories-eol14611.html

TECHNICAL SPECIFICATIONS

Dimensions and Weight

Table 28 HX-E-220M5SX Edge Dimensions and Weight

Parameter	Value
Height	1.7 in. (4.32 cm)
Width	16.89 in. (43.0 cm)
Depth	including handles: 18.98 in. (48.2 cm)
	29.8 in. (75.6 cm)
	including handles: 30.98 in. (78.7 cm)
Front Clearance	3 in. (76 mm)
Side Clearance	1 in. (25 mm)
Rear Clearance	6 in. (152 mm)
Weight	
Maximum (8 HDDs, 2 CPUs, 16 DIMMs, two power supplies)	37.5 lbs (17.0 kg)
Minimum (1 HDD, 1 CPU, 1 DIMM, one power supply)	29.0 lbs (13.2 kg)
Bare (0 HDD, 0 CPU, 0 DIMM, one power supply)	26.7 lbs (12.1 kg)

Power Specifications

The server is available with the following types of power supplies:

- 770 W (AC) power supply (see [Table 29](#)).
- 1050 W (AC) power supply (see [Table 30](#)).
- 1050 W V2 (DC) power supply (see [Table 31](#))

Table 29 HX-E-220M5SX Edge Power Specifications (770 W AC power supply)

Parameter	Specification			
Input Connector	IEC320 C14			
Input Voltage Range (V rms)	100 to 240			
Maximum Allowable Input Voltage Range (V rms)	90 to 264			
Frequency Range (Hz)	50 to 60			
Maximum Allowable Frequency Range (Hz)	47 to 63			
Maximum Rated Output (W)	770			
Maximum Rated Standby Output (W)	36			
Nominal Input Voltage (V rms)	100	120	208	230
Nominal Input Current (A rms)	8.8	7.4	4.2	3.8
Maximum Input at Nominal Input Voltage (W)	855	855	855	846
Maximum Input at Nominal Input Voltage (VA)	882	882	882	872
Minimum Rated Efficiency (%) ¹	90	90	90	91
Minimum Rated Power Factor ¹	0.97	0.97	0.97	0.97
Maximum Inrush Current (A peak)	15			
Maximum Inrush Current (ms)	0.2			
Minimum Ride-Through Time (ms) ²	12			

Notes:

1. This is the minimum rating required to achieve 80 PLUS Platinum certification, see test reports published at <http://www.80plus.org/> for certified values
2. Time output voltage remains within regulation limits at 100% load, during input voltage dropout

Table 30 HX-E-220M5SX Edge 1050 W (AC) Power Supply Specifications

Parameter	Specification
Input Connector	IEC320 C14
Input Voltage Range (V rms)	100 to 240
Maximum Allowable Input Voltage Range (V rms)	90 to 264
Frequency Range (Hz)	50 to 60
Maximum Allowable Frequency Range (Hz)	47 to 63

Table 30 HX-E-220M5SX Edge 1050 W (AC) Power Supply Specifications

	800		1050	
Maximum Rated Output (W) ¹				
Maximum Rated Standby Output (W)			36	
Nominal Input Voltage (V rms)	100	120	208	230
Nominal Input Current (A rms)	9.2	7.6	5.8	5.2
Maximum Input at Nominal Input Voltage (W)	889	889	1167	1154
Maximum Input at Nominal Input Voltage (VA)	916	916	1203	1190
Minimum Rated Efficiency (%) ²	90	90	90	91
Minimum Rated Power Factor ²	0.97	0.97	0.97	0.97
Maximum Inrush Current (A peak)			15	
Maximum Inrush Current (ms)			0.2	
Minimum Ride-Through Time (ms) ³			12	

Notes:

1. Maximum rated output is limited to 800W when operating at low-line input voltage (100-127V)
2. This is the minimum rating required to achieve 80 PLUS Platinum certification, see test reports published at <http://www.80plus.org/> for certified values
3. Time output voltage remains within regulation limits at 100% load, during input voltage dropout

Table 31 HX-E-220M5SX Edge 1050 W (DC) Power Supply Specifications

Parameter	Specification
Input Connector	Molex 42820
Input Voltage Range (V rms)	-48
Maximum Allowable Input Voltage Range (V rms)	-40 to -72
Frequency Range (Hz)	NA
Maximum Allowable Frequency Range (Hz)	NA
Maximum Rated Output (W)	1050
Maximum Rated Standby Output (W)	36
Nominal Input Voltage (V rms)	-48
Nominal Input Current (A rms)	24
Maximum Input at Nominal Input Voltage (W)	1154
Maximum Input at Nominal Input Voltage (VA)	1154
Minimum Rated Efficiency (%) ¹	91
Minimum Rated Power Factor ¹	NA
Maximum Inrush Current (A peak)	15
Maximum Inrush Current (ms)	0.2
Minimum Ride-Through Time (ms) ²	5

Notes:

1. This is the minimum rating required to achieve 80 PLUS Platinum certification, see test reports published at <http://www.80plus.org/> for certified values
2. Time output voltage remains within regulation limits at 100% load, during input voltage dropout

For configuration-specific power specifications, use the Cisco UCS Power Calculator at this URL:

<http://ucspowercalc.cisco.com>

Environmental Specifications

The environmental specifications for the HX-E-220M5SX Edge server are listed in [Table 32](#).

Table 32 Environmental Specifications

Parameter	Minimum
Operating Temperature	<p>Dry bulb temperature of 10°C to 35°C (50°F to 95°F)</p> <p>Maximum temperature change of 20°C (36°F) per hour (a temperature change within a specified period of time and not a rate of change)</p> <p>Humidity condition: Uncontrolled, not to exceed 50% RH starting condition</p> <p>Derate the maximum temperature by 1°C (33.8°F) per every 305 meters of altitude above 900m</p>
Extended Operating Temperature	<p>5°C to 40°C (41°F to 104°F) with no direct sunlight</p> <p>Humidity condition: Uncontrolled, not to exceed 50% RH starting condition</p> <p>Derate the maximum temperature by 1°C (33.8°F) per every 305 meters of altitude above 900m</p>
Non-Operating Temperature	Dry bulb temperature of -40°C to 65°C (-40°F to 149°F)
Operating Relative Humidity	<p>10% to 90% and 28°C (82.4°F) maximum dew-point temperature, non-condensing environment</p> <p>Minimum to be higher (more moisture) of -12°C (10.4°F) dew point or 8% relative humidity</p> <p>Maximum to be 24°C (75.2°F) dew point or 90% relative humidity</p>
Non-Operating Relative Humidity	5% to 93% relative humidity, non-condensing, with a maximum wet bulb temperature of 28°C across the 20°C to 40°C dry bulb range.
Maximum Operating Duration	Unlimited
Operating Altitude	A maximum elevation of 3050 meters (10,006 ft)
Non-Operating Altitude	An elevation of 0 to 12,000 meters (39,370 ft)
Sound Power level, Measure A-weighted per ISO7779 LWAd (Bels) Operation at 23°C (73°F)	5.5
Sound Pressure level, Measure A-weighted per ISO7779 LpAm (dBA) Operation at 23°C (73°F)	40

Extended Operating Temperature Hardware Configuration Limits

Table 33 Cisco HX-E-220M5SX Edge Extended Operating Temperature Hardware Configuration Limits

Platform ¹	ASHRAE A3 (5°C to 40°C) ²	ASHRAE A4 (5°C to 45°C) ³
Processors:	155W+	155W+ and 105W+ (4 or 6 Cores)
Memory:	LRDIMMs	LRDIMMs
Storage:	M.2 SATA SSDs	M.2 SATA SSDs
	NVMe SSDs	NVMe SSDs
Peripherals:	PCIe NVMe SSDs	MRAID
	GPUs	PCIe NVMe SSDs
		GPUs
		mLOMs
		VICs
		NICs
		HBAs

Notes:

1. Two PSUs are required and PSU failure is not supported
2. Non-Cisco UCS qualified peripherals and/or peripherals that consume more than 25W are not supported
3. High power or maximum power fan control policy must be applied

Compliance Requirements

The regulatory compliance requirements for C-Series servers are listed in [Table 34](#).

Table 34 UCS C-Series Regulatory Compliance Requirements

Parameter	Description
Regulatory Compliance	Products should comply with CE Markings per directives 2014/30/EU and 2014/35/EU
Safety	UL 60950-1 Second Edition CAN/CSA-C22.2 No. 60950-1 Second Edition EN 60950-1 Second Edition IEC 60950-1 Second Edition AS/NZS 60950-1 GB4943 2001
EMC - Emissions	47CFR Part 15 (CFR 47) Class A AS/NZS CISPR32 Class A CISPR32 Class A EN55032 Class A ICES003 Class A VCCI Class A EN61000-3-2 EN61000-3-3 KN32 Class A CNS13438 Class A
EMC - Immunity	EN55024 CISPR24 EN300386 KN35



Americas Headquarters
Cisco Systems, Inc.
San Jose, CA

Asia Pacific Headquarters
Cisco Systems (USA) Pte. Ltd.
Singapore

Europe Headquarters
Cisco Systems International BV Amsterdam,
The Netherlands

Cisco has more than 200 offices worldwide. Addresses, phone numbers, and fax numbers are listed on the Cisco Website at www.cisco.com/go/offices.

Cisco and the Cisco Logo are trademarks of Cisco Systems, Inc. and/or its affiliates in the U.S. and other countries. A listing of Cisco's trademarks can be found at www.cisco.com/go/trademarks. Third party trademarks mentioned are the property of their respective owners. The use of the word partner does not imply a partnership relationship between Cisco and any other company. (1005R)

